



IDENTJET M8-3

1 Barcode Printer	1
1-1 Package Contains	1
1-2 Barcode Printer Introduction	2
2 Barcode Printer Installation	4
2-1 Media Installation	4
2-2 Printing Mechanism Opening	5
2-3 Ribbon Installation	6
(4 inch Ribbon)	6
(8 inch Ribbon)	7
2-4 Label Installation	9
2-5 Connection with PC	12
2-4 Driver and Golabel Installation	13
2-10 Wizard CD Other Choice Installation	16
3 Barcode Printer Operation	19
3-1 Barcode Printer Operation Interface	19
3-3 LAN Setting Operation Instruction	25
Main Menu	25
3-5 Error Message	32
4 Installing the NetSetting software	37
4-2 The Interface of NetSetting	39
5 Barcode Printer Options	46
5-1 Pre -step for Options Installation	46
5-2 Cutter Installation	47
6 Maintenance and Adjustment	51
6-1 Print Head Replacement	51
6-2 Print Line Adjustment	52
6-4 Print Head Cleaning	54
6-5 Print Head Pressure Adjustment	54
6-6 Ribbon Wrinkle Adjustment	56
6-7 Cutter Error Trouble Shooting	56
6-8 Trouble Shooting	58
Appendix - Printer Specification	59
Appendix - Communication Port Specification	60
Appendix – Wi-Fi Setting	59
Appendix – Bluetooth Setting	66
Appendix – FILE MANIPULATION WHEN USING USB STICK	78

Printer Compliance Insert



Note: This equipment may be used on an IT power system.

For Users in English Speaking Regions (en)



Caution: This marking indicates that the user should read all included documentation before use.

The users of this product are cautioned to use accessories and peripherals approved by manufacturing company. The use of accessories other than those recommended, or changes to this product that are not approved by manufacturing company, may void the compliance of this product and may result in the loss of the user's authority to operate the equipment.



Caution: For power supply, use manufacturing company. No user-serviceable parts.

FCC Digital Emissions Compliance

This equipment has been tested and found to comply with the limits for a CLASS A digital device, pursuant to Part 15 of the FCC Rules. These limits are designed to provide reasonable protection against harmful interference when the equipment is operated in a commercial environment. This equipment generates, uses, and can radiate radio frequency energy and, if not installed and used in accordance with the instructions, may cause harmful interference to radio communications. Operation of this equipment in a residential area is likely to cause harmful interference in which case the user will be required to correct the interference at own expense.

Canadian Digital Apparatus Compliance

This Class A digital apparatus meets all requirements of the Canadian Interference-Causing Equipment Regulations.

CE Marking: Refer to the Declaration of Conformity for a list of the EU Directives and Standards that this product complies with.

Für Anwender in Deutschland (de)



Vorsicht: Diese Kennzeichnung weist darauf hin, dass der Benutzer vor dem Gebrauch alle mitgelieferten Unterlagen lesen soll.

Die Benutzer dieses Produkts werden darauf hingewiesen, nur Zubehörteile und Peripheriegeräte zu verwenden, die vom Hersteller genehmigt sind. Falls nicht empfohlene Zubehörteile verwendet oder an diesem Produkt Änderungen vorgenommen werden, die nicht vom Hersteller genehmigt sind, kann dadurch die behördliche Konformität des Produkts verletzt werden und der Benutzer die Berechtigung zur Verwendung des Geräts verlieren.



Vorsicht: Nur das beigelegte original Netzteil verwenden. Enthält keine Teile, die vom Benutzer gewartet werden können.

CE-Kennzeichnung: Die Konformitätserklärung enthält eine Liste der EU-Richtlinien und Normen, denen das Produkt entspricht.

Warnhinweis

Dies ist ein Produkt der Klasse A. In Wohnumgebungen kann dieses Produkt Funkstörungen verursachen. In diesem Fall obliegt es dem Anwender, angemessene Maßnahmen zu ergreifen.

Pour les utilisateurs canadiens et français (fr)



Attention: Ce marquage indique que l'utilisateur doit, avant l'utilisation, lire toute la documentation incluse.



Attention: Pour la source d'alimentation, utilisez fabricants. Il ne contient aucune pièce réparable par l'utilisateur.

Utilisateurs de ce produit sont avisés d'utiliser des accessoires et des périphériques approuvés par fabricants. L'utilisation d'accessoires autres que ceux recommandés ou des changements à ce produit qui ne sont pas approuvés par fabricants, peuvent annuler la conformité de ce produit et mettre fin au droit qu'a l'utilisateur d'utiliser l'équipement.

Conformité aux normes canadiennes sur les appareils numériques

Cet appareil numérique de la classe A respecte toutes les exigences du Règlement sur le matériel brouilleur du Canada.

AVERTISSEMENT: Il s'agit d'un produit de classe A. Dans un environnement domestique, ce produit pourra provoquer des interférences radio auquel cas l'utilisateur pourrait avoir à prendre de mesures adéquates.

適用於臺灣使用者 (zh-tw)



注意：此標誌表示使用者應在使用前先閱讀所有隨附的文件。

本產品的使用者必須小心使用製造商許可的配件與週邊設備。使用非上述建議的配件，或是在未經製造商許可的情況下變更本產品可能會使得本產品的相容性失效，並且使得使用者喪失操作設備的權力。



請使用製造商電源。無使用者可自行維修之零件。

사용자안내문

이 기기는 업무용 환경에서 사용할 목적으로 적합성평가를 받은 기기로서 가정용 환경에서 사용하는 경우 전파간섭의 우려가 있습니다

FCC COMPLIANCE STATEMENT

FOR AMERICAN USERS

Federal Communication Commission Interference Statement

This equipment has been tested and found to comply with the limits for a Class B digital device, pursuant to Part 15 of the FCC Rules. These limits are designed to provide reasonable protection against harmful interference in a residential installation. This equipment generates, uses and can radiate radio frequency energy and, if not installed and used in accordance with the instructions, may cause harmful interference to radio communications. However, there is no guarantee that interference will not occur in a particular installation. If this equipment does cause harmful interference to radio or television reception, which can be determined by turning the equipment off and on, the user is encouraged to try to correct the interference by one of the following measures:

- Reorient or relocate the receiving antenna.
- Increase the separation between the equipment and receiver.
- Connect the equipment into an outlet on a circuit different from that to which the receiver is connected.
- Consult the dealer or an experienced radio/TV technician for help.

This device complies with Part 15 of the FCC Rules. Operation is subject to the following two conditions:

(1) This device may not cause harmful interference, and (2) this device must accept any interference received, including interference that may cause undesired operation.

FCC Caution: Any changes or modifications not expressly approved by the party responsible for compliance could void the user's authority to operate this equipment.

TO WHICH THIS DECLARATION RELATES

IS IN CONFORMITY WITH THE FOLLOWING STANDARDS

FCC CFR Title 47 Part 15 Subpart B:2015 Class B, CISPR 22:2008 ANSI C63.4: 2014 ICES-003 Issue 6:2016, Class B

IEC 60950-1:2005(Second Edition)+Am1:2009+Am2:2013

EN55024:2010+A1:2015

EN55032:2012+AC:2013, Class B

EN61000-3-2:2014

EN61000-3-3:2013

AS/NZS CISPR 22:2009+A1:2010

SAFETY INSTRUCTIONS

Please read the following instructions carefully.

- **Keep the equipment away from humidity.**
- **Before you connect the equipment to the power outlet, please check the voltage of the power source.**
- **Make sure the printer is off before plugging the power connector into the power jack.**
- **It is recommended that you connect the printer to a surge protector to prevent possible transient overvoltage damage.**
- **Be careful not to get liquid on the equipment to avoid electrical shock.**
- **For safety and warranty reasons, ONLY qualified service personnel should open the equipment.**
- **Do not repair or adjust energized equipment under any circumstances.**

CAUTION

- **Danger of explosion if battery is incorrectly replaced. Replace only with the equivalent type recommended by the manufacturer.**
- **Dispose of used batteries according to the manufacturer's instructions.**
- **Only use with designated power supply adapter model.**
- **Changes or modifications not expressly approved by the party responsible for compliance could void the user's authority to operate the equipment.**

Specifications are subject to change without Note

1 Barcode Printer

1-1 Package Contains

Please check that all of the following items are included with your printer.

(Package content and Logo style may vary per region °)

- Barcode Printer

IDENTjet M8-3

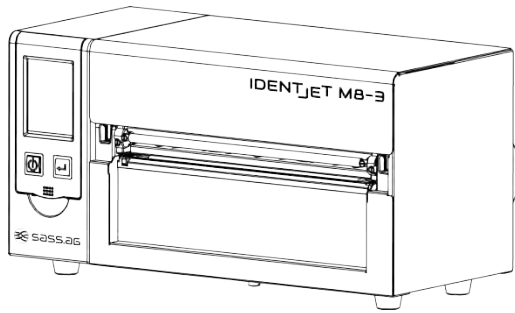

- Label Roll Stopper

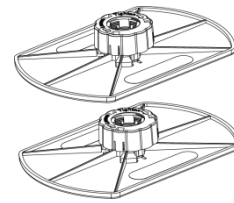

Media Sample

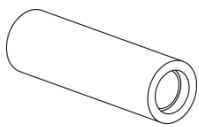

USB cable

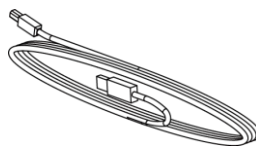

Quick Start Guide



Ribbon

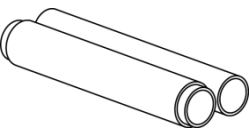

Power Cord

(EU)

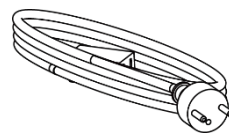

CD

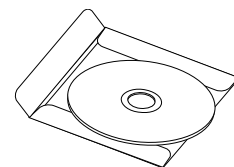

1.5 inch/3 inch Adaptor

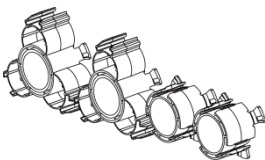

Power Cord

(US)

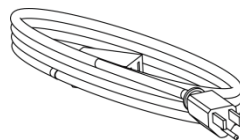

Ribbon Shaft

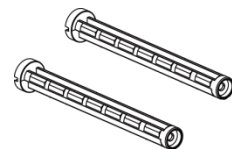

Label Roll Holder

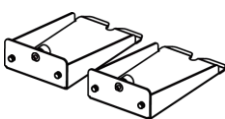

Media Holder Base

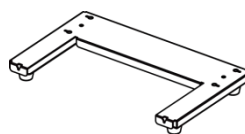

Media Shaft



1-2 Barcode Printer Introduction

Front View

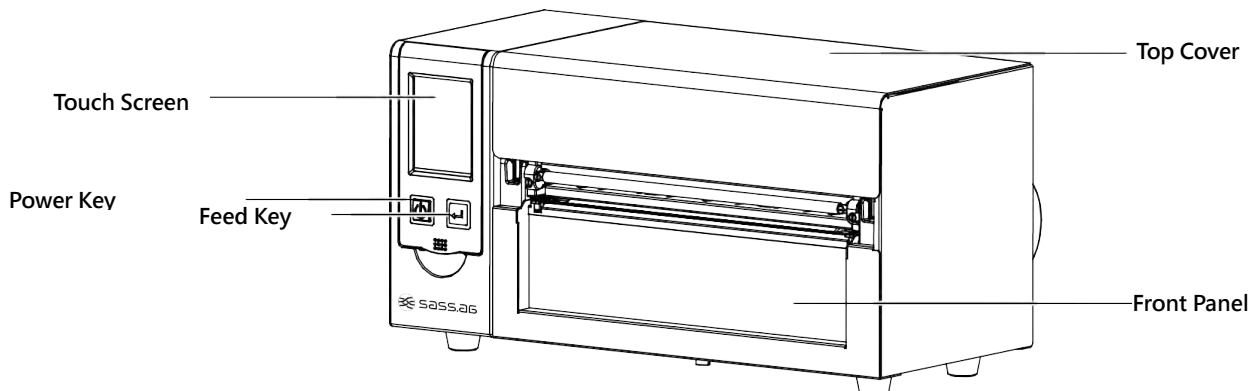

Rear View

(Interface might differed per Optional interface)

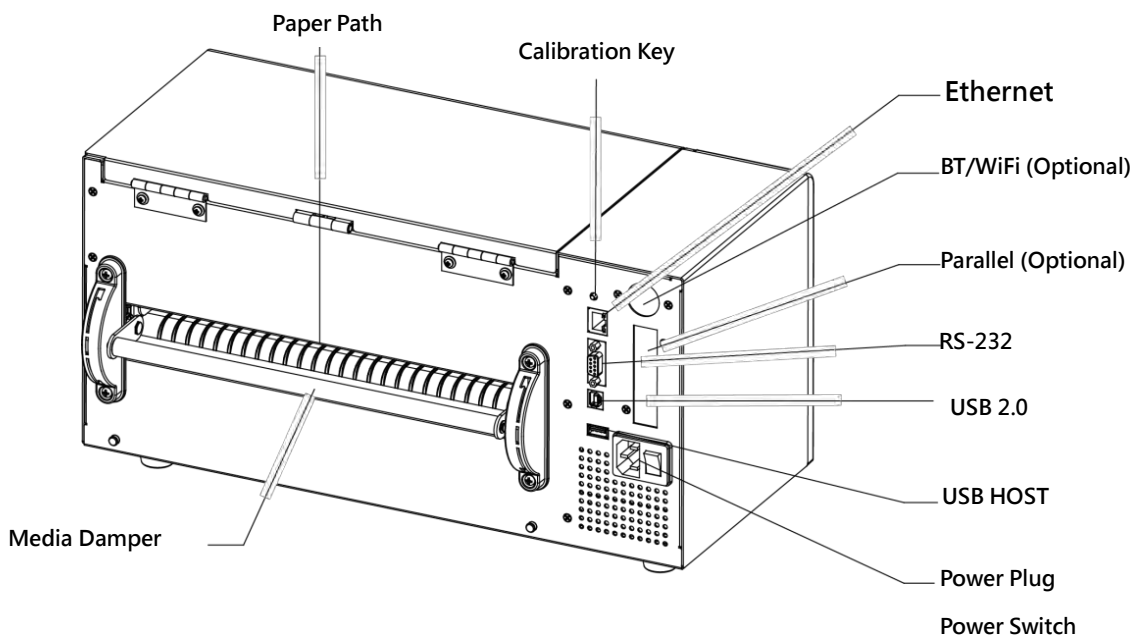

Open Top Cover

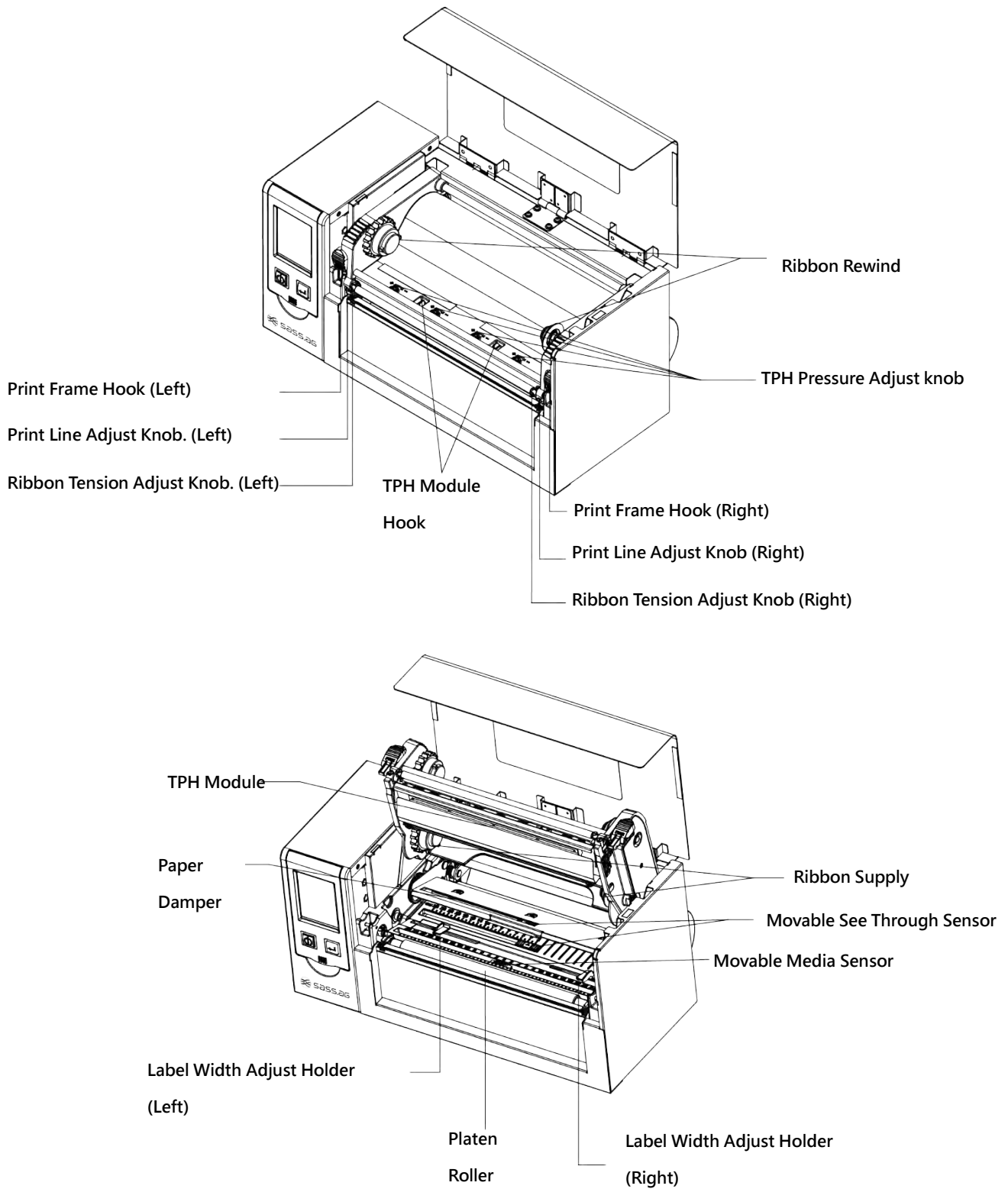

2 Barcode Printer Installation

2-1 Media Installation

- Lift up the top cover

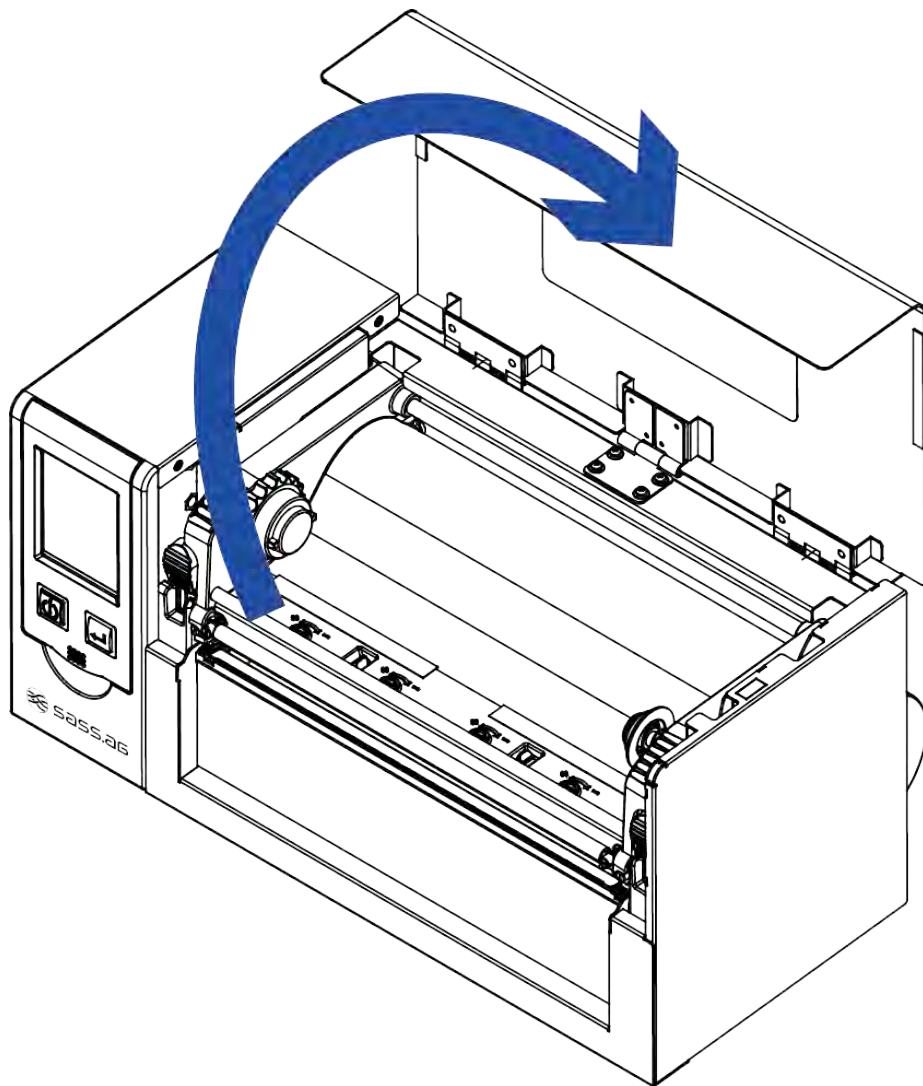

2-2 Printing Mechanism Opening

- Push the Print frame hook on the side to head up the print frame.

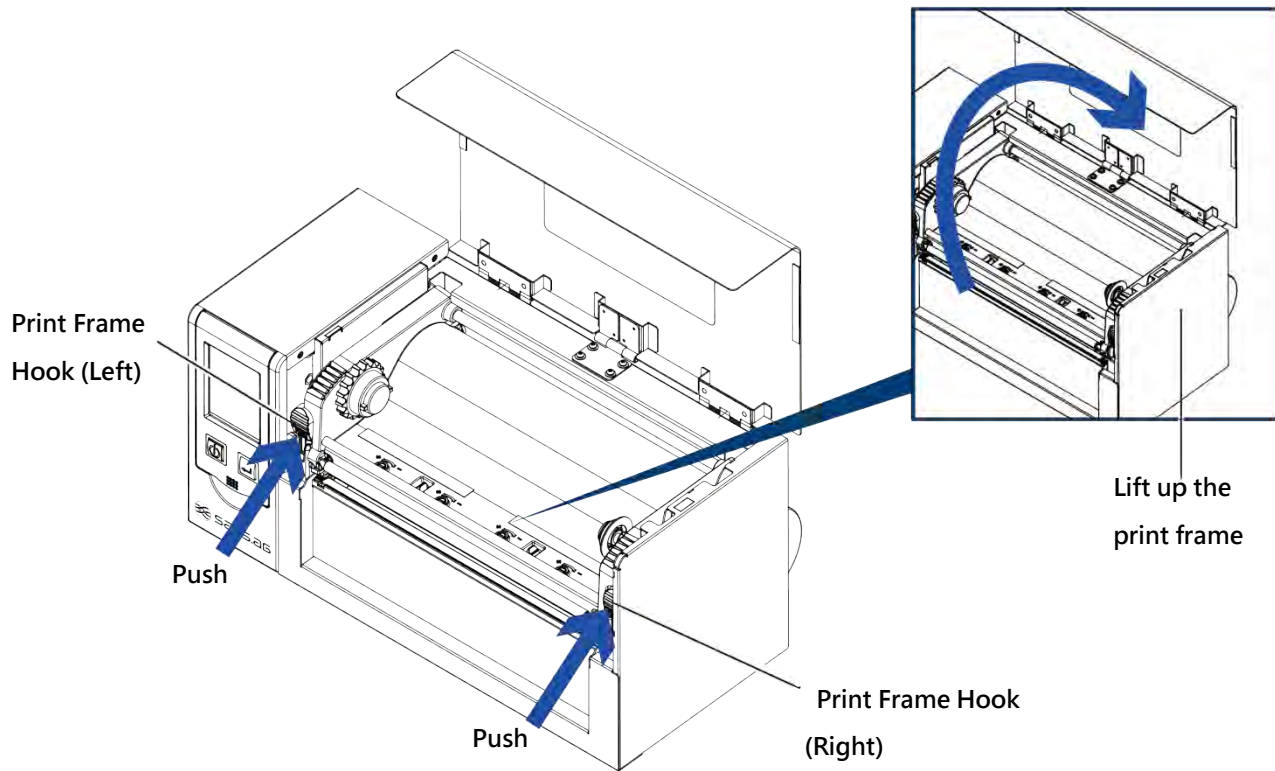

2-3 Ribbon Installation

(4 inch Ribbon)

- Plug a new ribbon roll into the ribbon Shaft

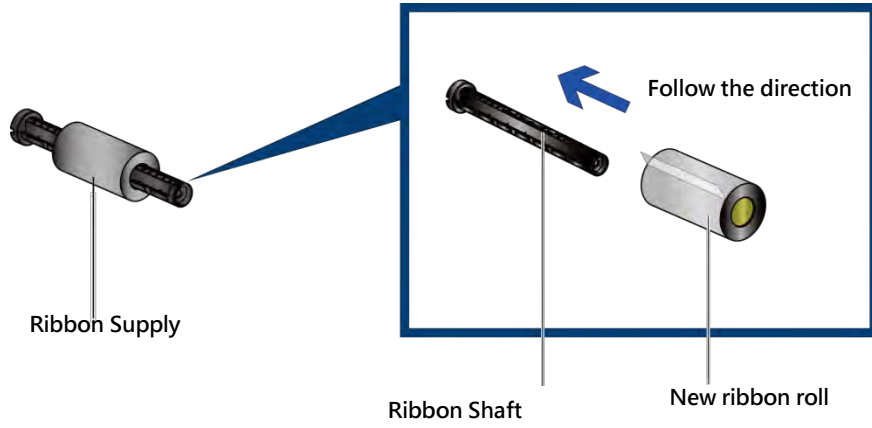

Install the empty ribbon core into ribbon shaft

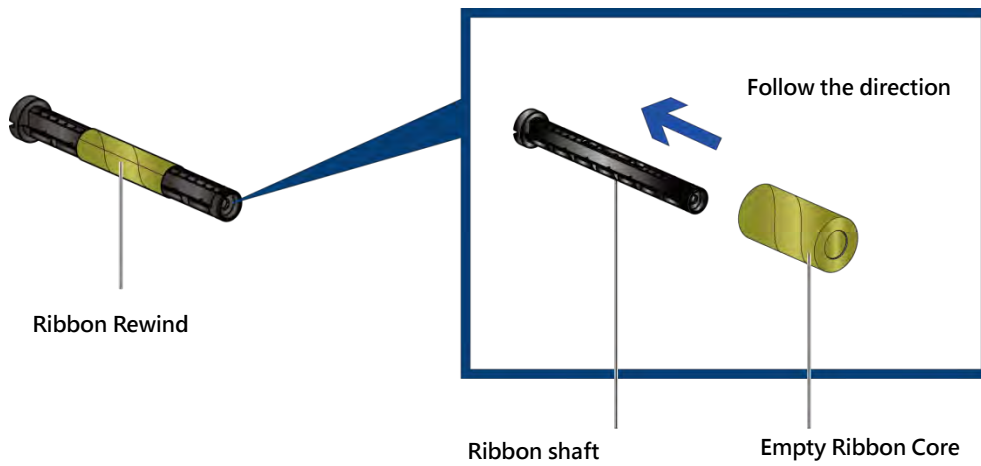

Stick the ribbon with the Ribbon Rewind units and rolling 2~3 cycles.

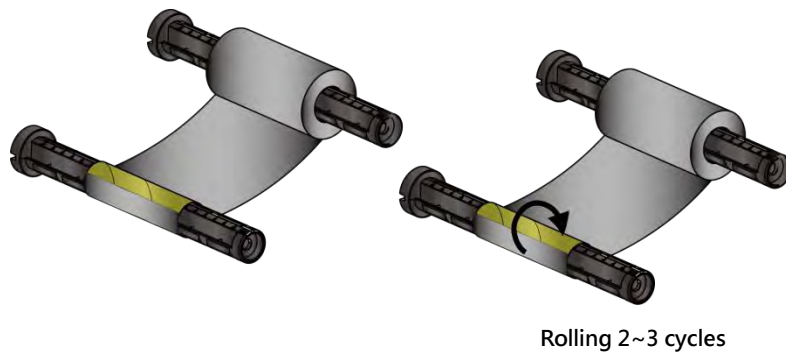

(8 inch Ribbon)

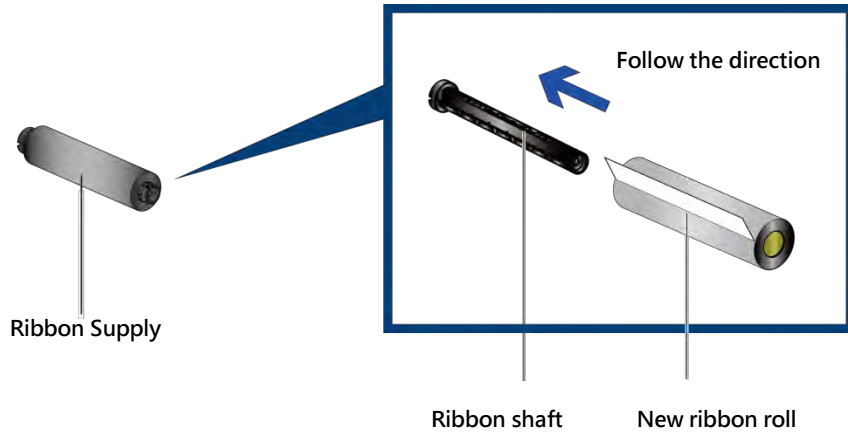

Install the empty ribbon core into ribbon shaft

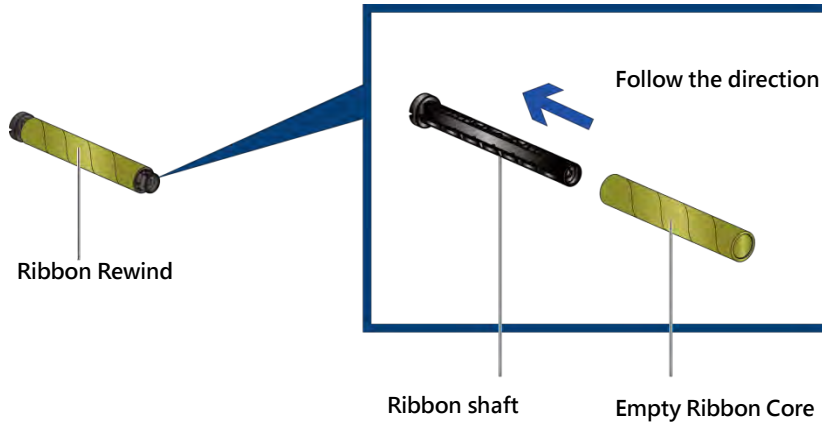

Stick the ribbon with the Ribbon Rewind units and rolling 2~3 cycles

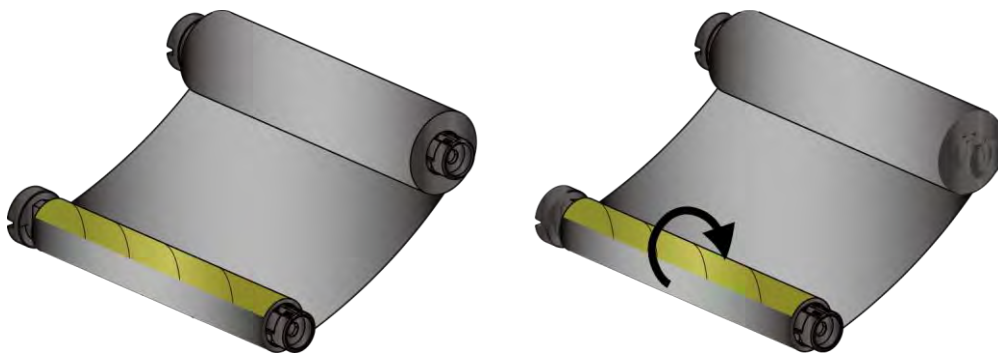

Rolling 2~3 cycles

➤ **Install the Ribbon into the Barcode Printer**

Follow the below drawing to install the ribbon in position.

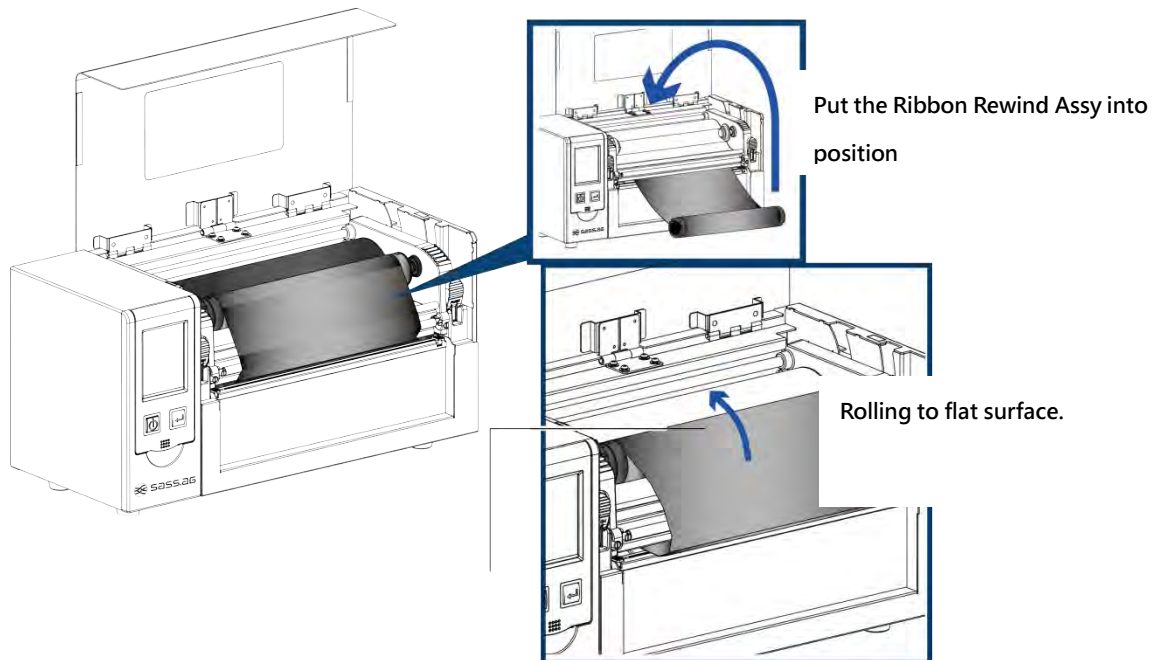
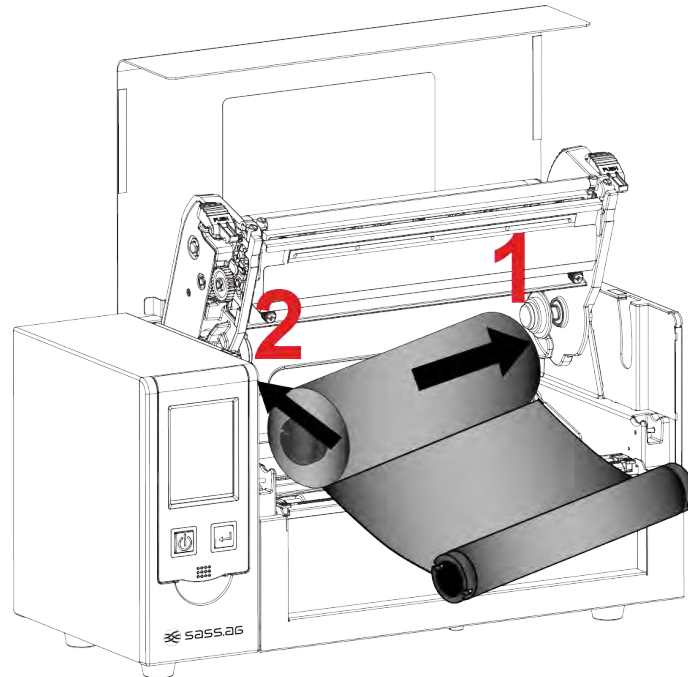

2-4 Label Installation

➤ Label Roll Ass'y

Put the label roll into media spindle and then install the label roll stopper on the both side to make the media roller in position.

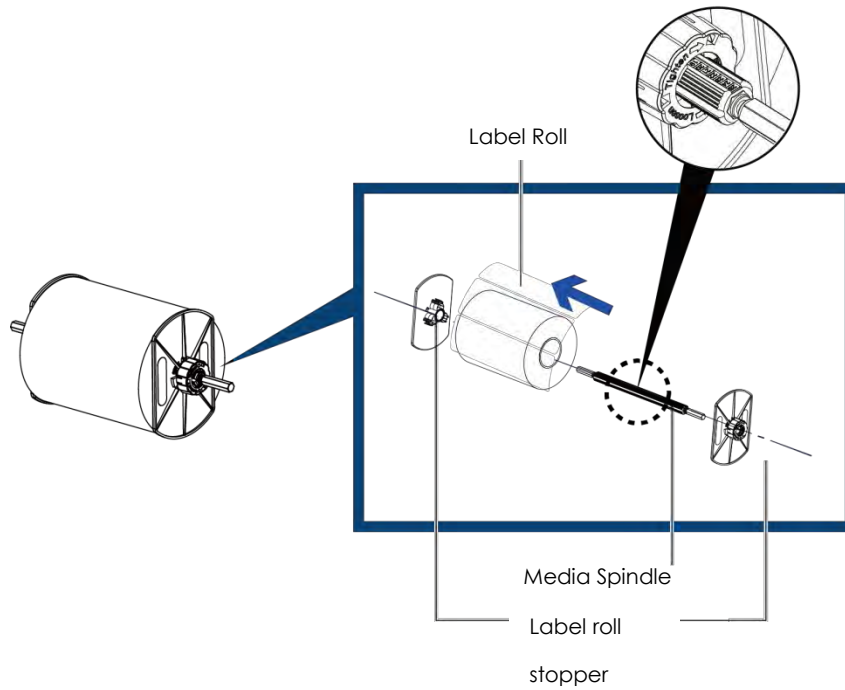

➤ Label Holder Stand

Follow the direction to secure the core adaptor

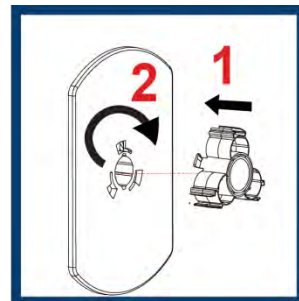

Follow the Arrow mark and No. to assemble the stand.

Follow the Arrow mark and No. to assemble the stand.

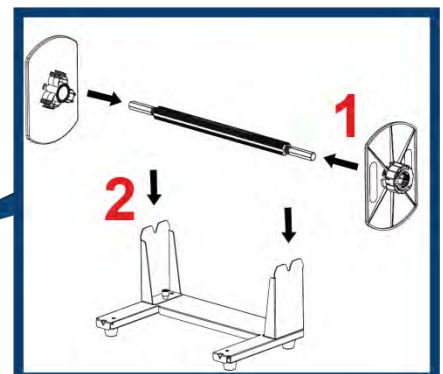
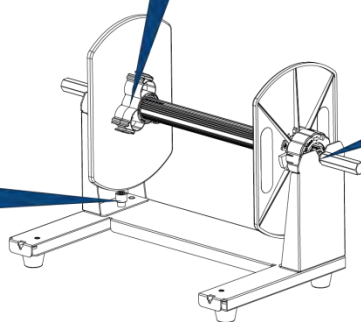
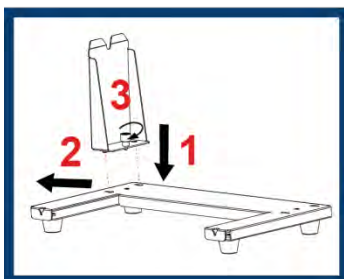

➤ **Label Installation**

Step 1. Following the arrow mark and No. to put the label roll holder into position.

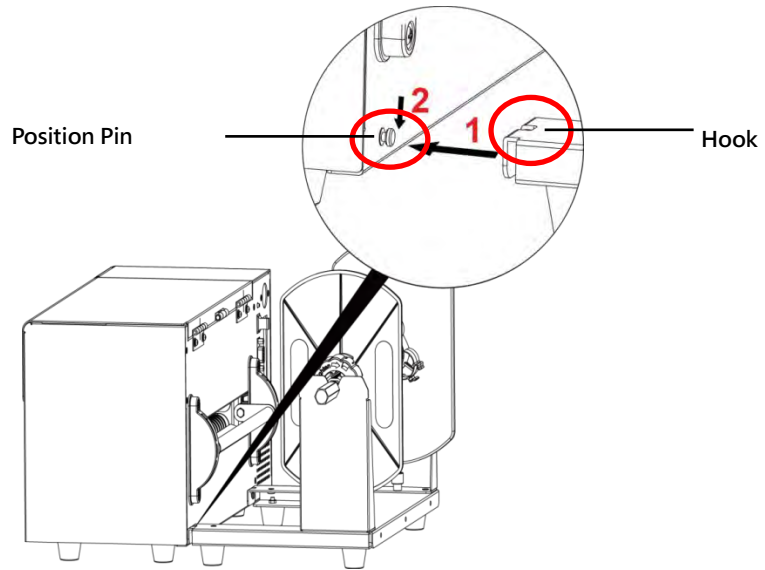

Step 2. Following the below arrow mark and direction to put the label roll into position.

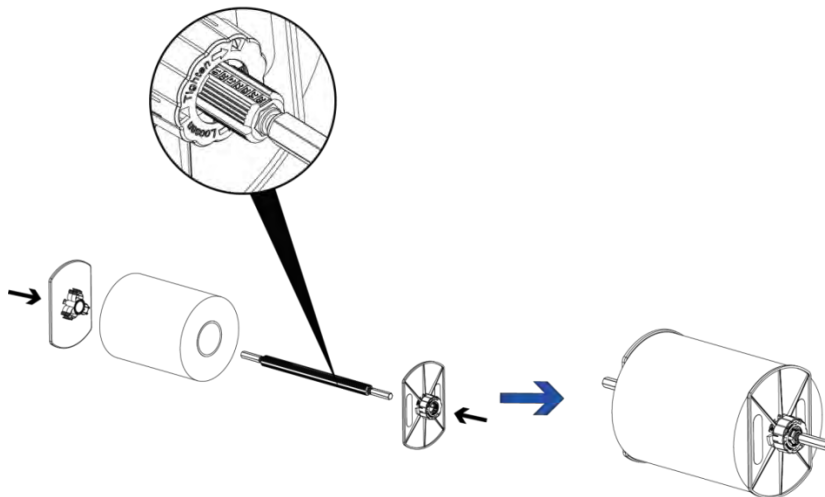

Step 3. Put the label roll into label roll stand.

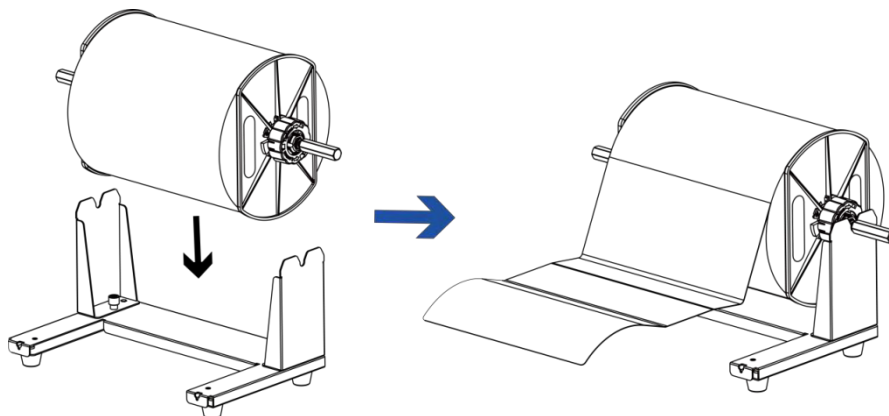

Step 4. Put the label pass through the label guide and then adjust the suitable label width according to.

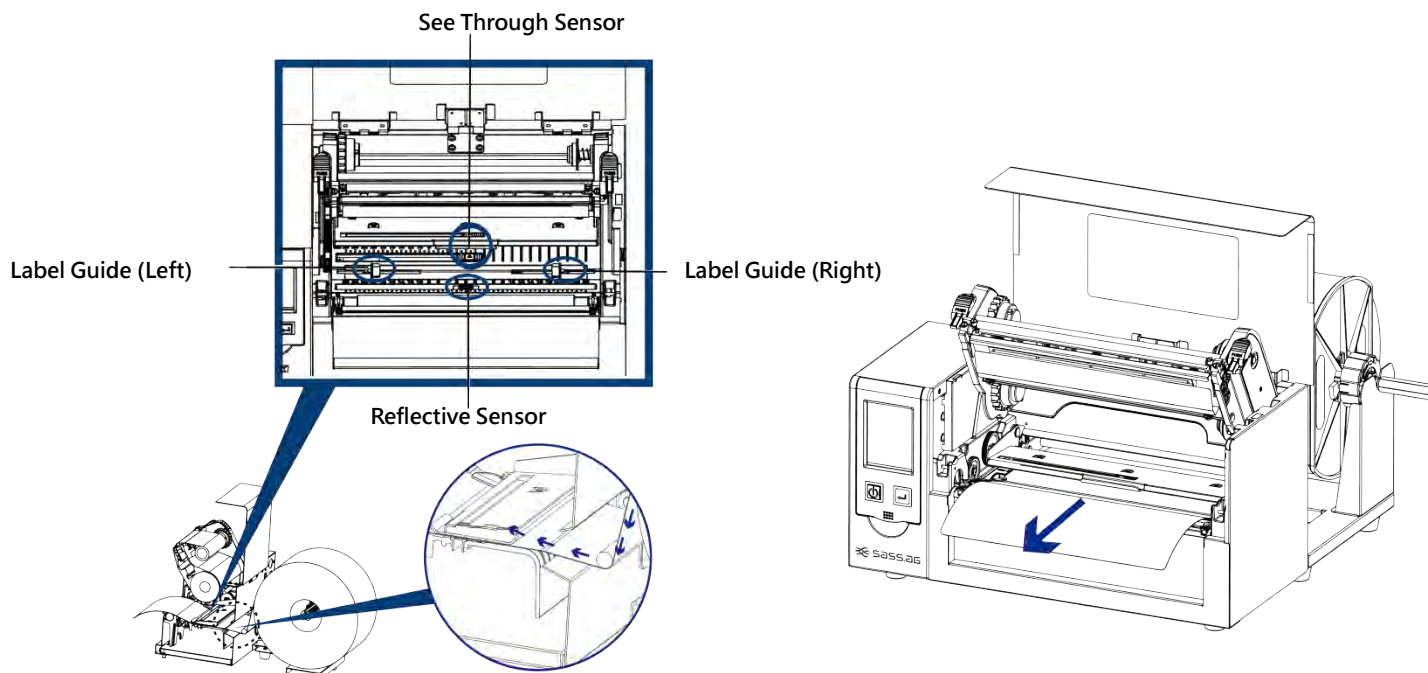

**Inside Label Roll
Installation**

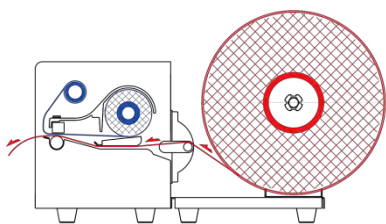

**Outside Label
Roll Installation**

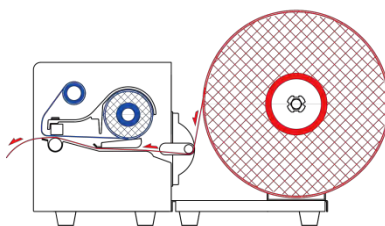

**Fanfold paper
Installation**

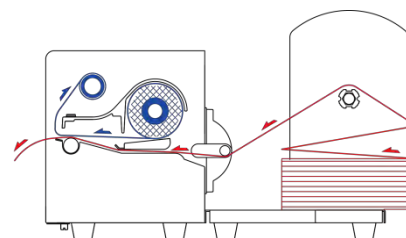

2-5 Connection with PC

1. Make sure the Barcode Printer power is in off status.
2. Put the power cord one side on the power plug, one side on the power adaptor.
3. Connect the transmission cable in between PC and printer (The cable might be differed according to option selected) .
4. After the media (ribbon) installation, then power on the printer, wait the status turned to ready.

HD830i Barcode Printer

(The interface might be differed upon the options been selected)

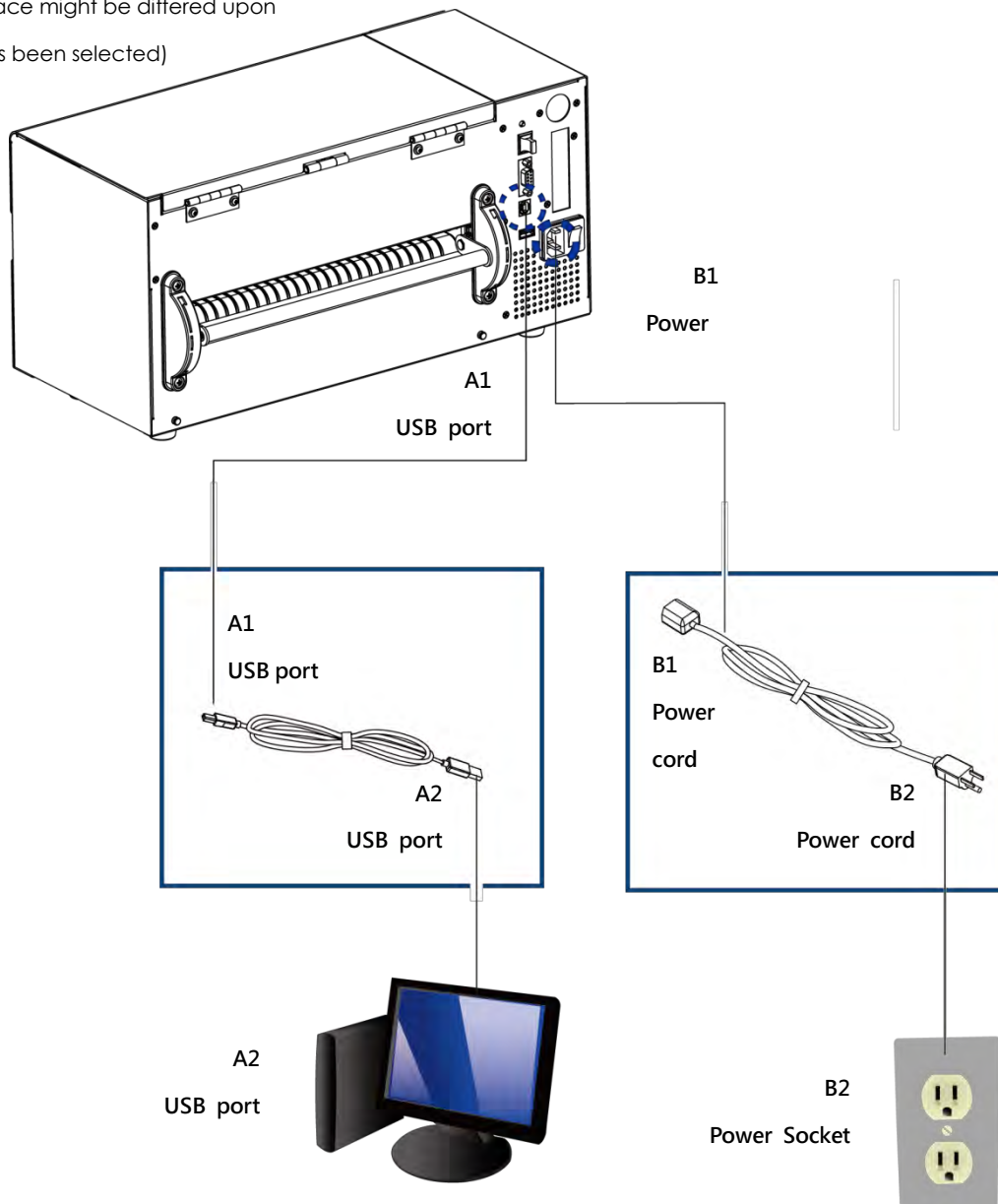

2-4 Driver and OpenLABEL Installation

Step.01 ➔ Insert the Super Wizard CD in the CD/DVD drive of the host computer and the installation program should pop up automatically. You will see the Welcome screen first. On the Welcome screen, choose "STANDARD INSTALLATION".



Step.02 ➔ The wizard will then ask you to make sure your USB and power cables are connected and that the power is turned on. Then click "NEXT".

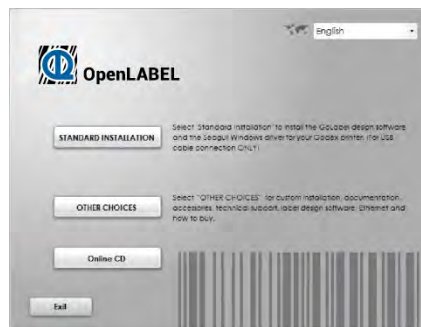

Step.03 ➔ The next screen you will see is, "Install the OpenLABEL Software and Windows driver". Click "NEXT" to continue.

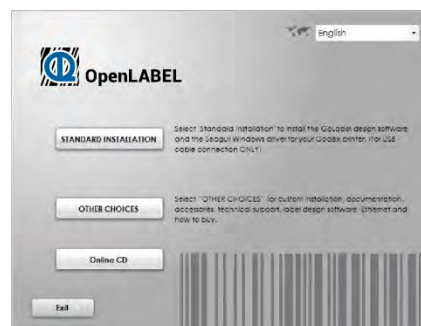

NOTE

* If the Super Wizard program did not run automatically, you can either turn on the "Auto-run" setting for your CD/DVD driver or double-click the icon of CD/DVD driver to run the program manually.

Step.04 ➔ As the printer driver and OpenLABEL are installing, a screen will display a progress bar. While downloading completed you will see Installation completed. Click "NEXT" to continue.

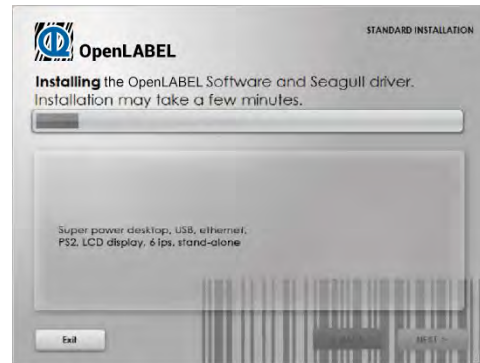
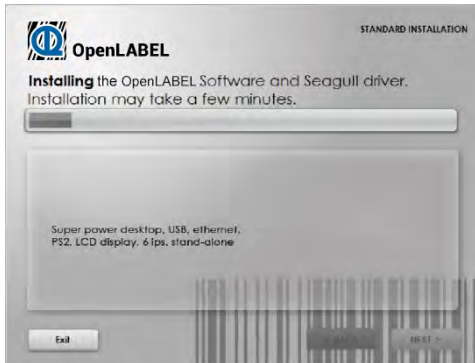

Step.05 ➔ You can also print a test label. If don't print a test label, the screen display as step 6.



Note

* If you need more resources, tools or reference documents, you can also find them on Super Wizard CD. Just click "Other Choices" on the Welcome Screen to access the files.

Step.06 ➔ Once the installation is complete, you can start to make and print labels with OpenLABEL or through the printer driver.

2-10 Wizard CD Other Choice Installation

Step.01 ➔ Click "OTHER CHOICES" to next screen and select "PRINTER DRIVERS".

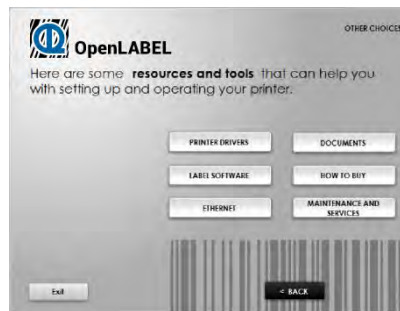
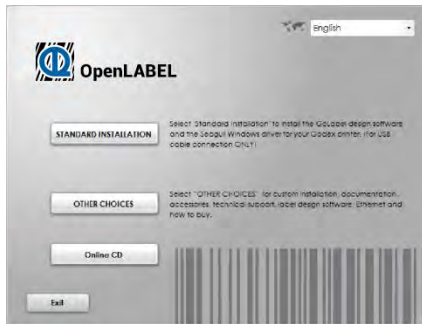

Step.02 ➔ Click "INSTALL SEAGULL SCIENTIFIC WINDOWS DRIVER" to next screen, and click "NEXT".

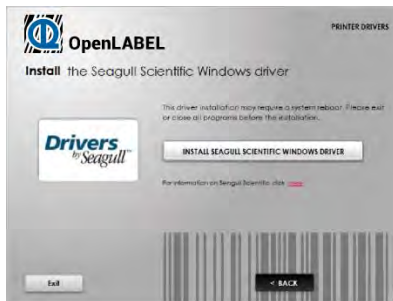

Step.03 ➔ Select "I accept the terms in the license agreement", and click "Next" · then click "Finish" to step 4.



Step.04 ➔ The Driver Wizard will guide you through the installation procedure. Select "Install printer drivers" and click "Next".



Step.05 ➔ With a USB connection, search models such as the right diagram printer device. Specify your printer model and click "Next".

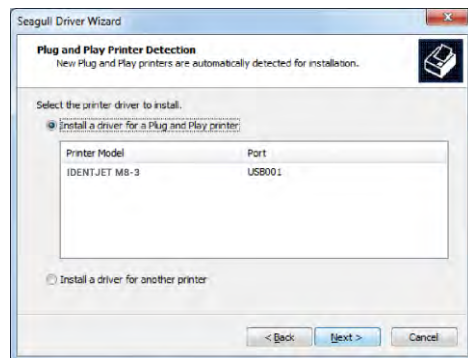
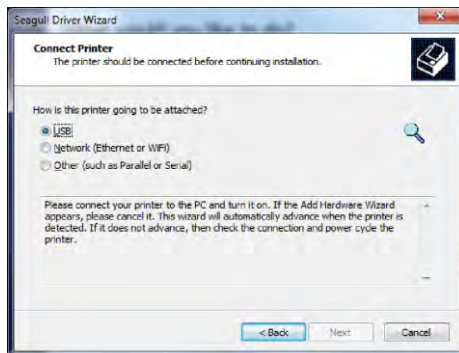

Step.06 ➔ Enter the printer name (you can use default), then click "Next" to display as right diagram. Click "Finish" button to start installation.



Step.07 ➔ Driver installation completed.

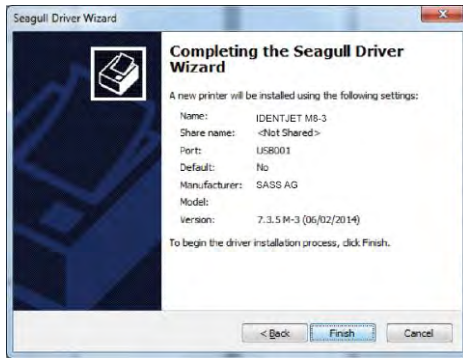

3 Barcode Printer Operation

3-1 Barcode Printer Operation Interface

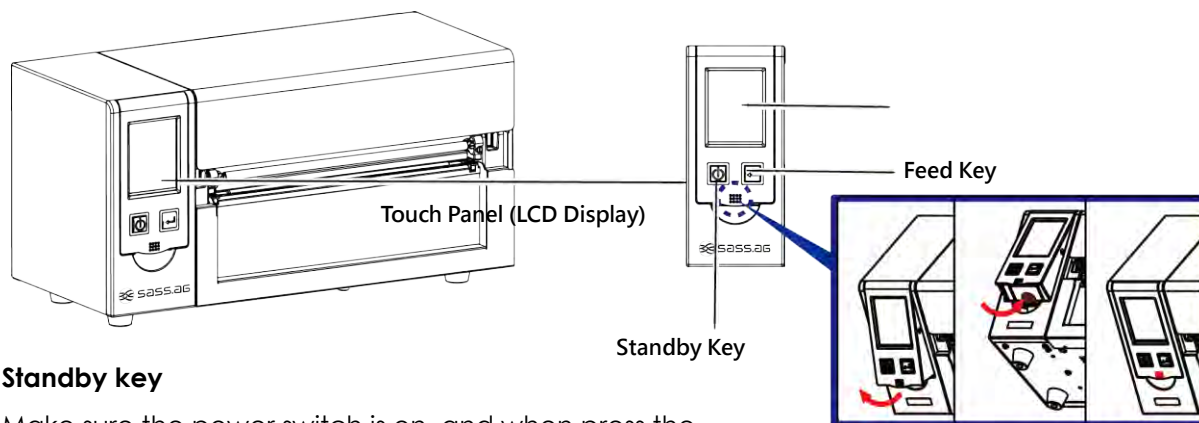

Standby key

Make sure the power switch is on, and when press the "Standby key", the Touch panel (LCD Display) will light up and show "Ready". When press and hold the "standby key" in 3 seconds, then the printer will be getting into "standby" mode.

Feed key

When you press the FEED button, the printer moves the label to the defined stop position. If you are using continuous labels, pressing the FEED button will move label stock until you release the button again. If you are using individual labels, pressing the FEED button will move only one label. If the label does not stop at the correct position, please run the auto calibration (See Section 3-6. for the label size calibration function) on the label stock.

Pause _ Feed key

If you want to pause the printing, just press the feed key then the printer will be on pause status, besides, the LCD will show "Pause" till you press the feed key again the printer will not print any further.

EX, if the printer is setting for 10 pages printing, when user press the feed key during the 2nd pages printing, the printer will stop printing till feed key been pressed again.

Cancel Printing_ Feed key

Press and hold feed key in 3 seconds during printing, the Printer will be backed to standby mode and LCD will display "Standby"and the printing job has been cancelled.

EX. If the printer is setting for 10 pages printing, when user press the feed key during the 2nd pages printing, the printer will stop printing from the 3rd page and back to Standby condition since the rest printing job has been cancelled.

3-2 LCD Operation Introduction

Getting Started

Press the POWER button to turn on the printer, and the START UP SCREEN appears.



If the printer is on "ready to print" status, the LCD screen should display the message "Ready" on the screen. Use touch gestures to get around the main screen and other screen for setting.



Tap the screen with your finger when you want to select on screen items such as settings icons.

On the Ready Page, three function mode for setting. You can make various setting functions in FUNCTIONAL MODE.



Tap "Main" –
Screen could show more detail of "Main"



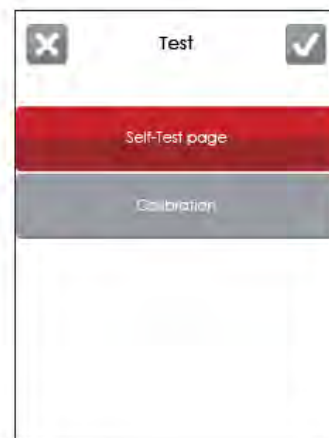

Tap "Wizard" –
Set up printer of "Darkness" "Speed" ...

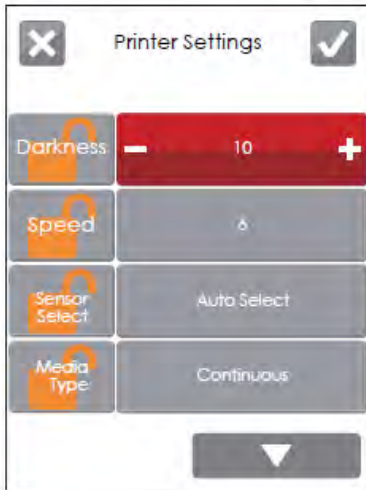

Tap "Test" –
Self-Test page and Calibration for setting.



finish setting tap 
 back to Main page, if
 do not save, tap 
 system back to
 Main page and
 would not save
 any changes.

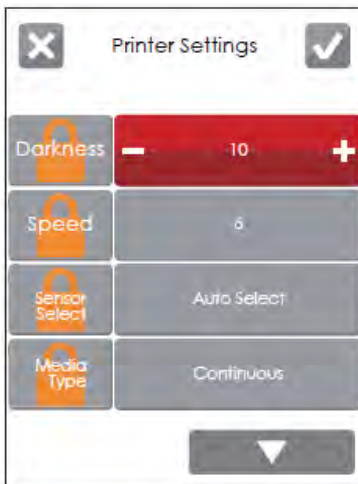

If printer functions locked, printer can not modify settings
 from OpenLABEL or any devices.

Keyboard Mode

When plug-in an USB keyboard to the printer, LCD touch panel will display "Enter Standalone", press the "Y" key on keyboard to entering to the dialog for "Keyboard Mode" operation.

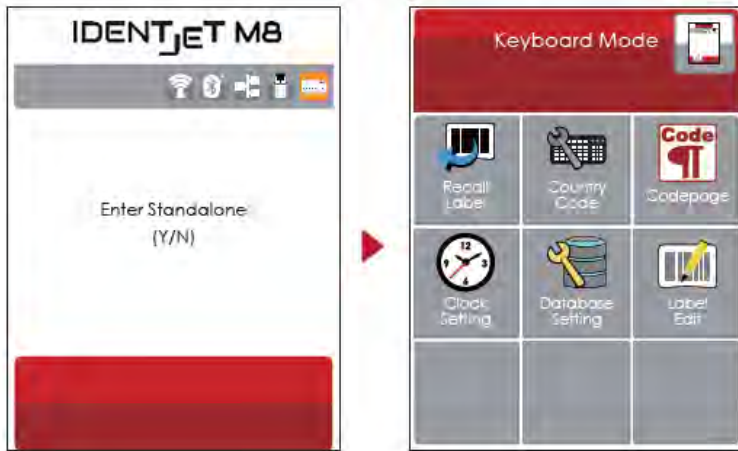

Preview Label function

User can choose any labels to preview it before print it.

From the "Ready" page, tap  to Main page
From the Main page tap Recall Label to Recall Label page.

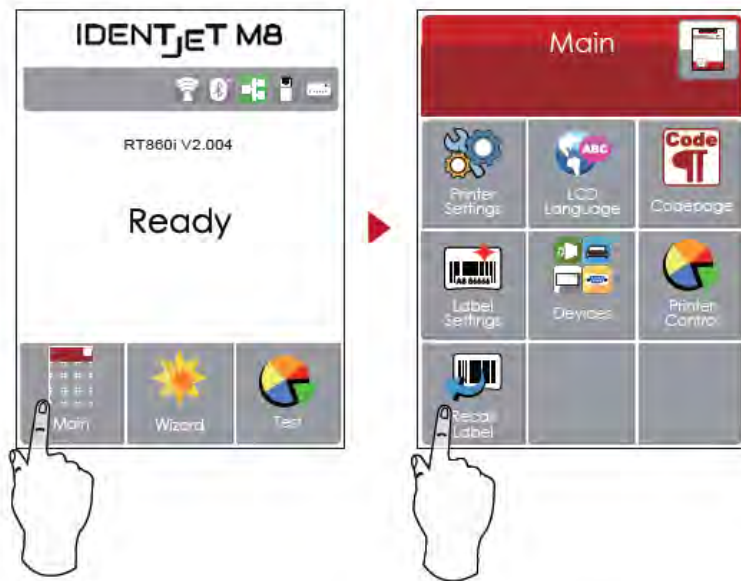

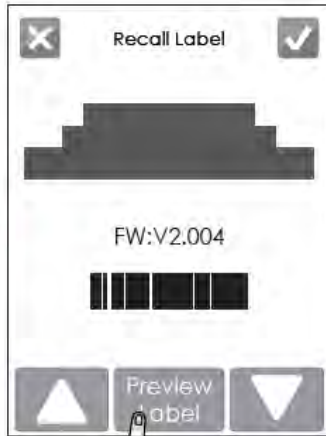

From the Recall Label Page the touch panel shown on all labels. The Data processing time will be extend as long as the labels increase.



Tap up to choose labels.



Tap down to choose labels.



Tap Preview Label can see printing label.

Keeping tap  to next page 

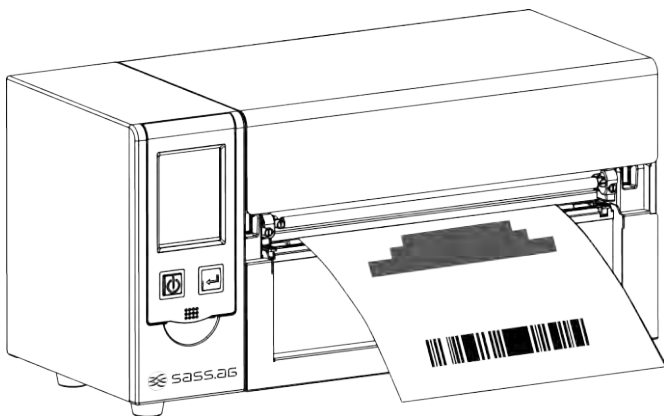

Label has been printed

3-3 LAN Setting Operation Instruction

Main Menu

Main Page



Setting items for printer, ex. Printing speed, darkness. Also includes a Printing Wizard for your ease of printing.



10 languages for printer setting



It consists of a table of values that describes the character set for a particular language



Setting items for printing label, ex. Rotation, Printing position offset



Providing Buzzer, Option Setting, Smart Backfeed, Serial Port Setting, LAN Setting, LCD Setting, Clock Setting, WiFi Setting, and Bluetooth Setting



Self-Diagnose functions for printer, ex. Calibration, Self-Test page and Clear Memory



Recall Label and preview label

Device Page



Setting off or on for buzzer



Setting items for options, ex. Cutter, Label Dispenser, Applicator



Setting off or on for Preview Label



Setting items for Serial Port, ex. Baud Rate, Parity, Data Bits, Stop Bits.



Setting items for LAN, ex. DHCP, IP Address, Subnet Mask, Gateway



Setting items for LCD, ex. off or on for Password function, Correction



Setting items for Clock, ex. Year, Month, Day, Hour, Minute and off or on for Visible function

Setting Items in LCD Setting Mode



	Darkness	0-19
	Speed	2-9
	Sensor Select	Auto Select See-Through Reflective
	Media Type	Label with Gaps Label with Marks Continuous
Printer Settings	Printing Mode	Direct Thermal Thermal Transfer
	Tear-off Position	0-40
	Top of Form	OFF FULL Door Open Only
	Program Language	Auto EZPL GEPL GZPL



LCD Language	English
	Deutsch
	Français
	Español
	Italiano
	繁體中文
	簡體中文
	Türkçe
	日本語
	Русский



Code Page	850
	852
	437
	860
	863
	865
	857
	861
	862
	855
	866
	737
	851
	869
	Windows 1252
	Windows 1250
	Windows 1251
	Windows 1253
	Windows 1254
	Windows 1255
	Windows 1257



Label Settings	Rotation (0° - 90° - 180° - 270°)
	X-Offset (-100 ~ +100)
	Y-Offset (-100 ~ +100)
	Start Offset (-100 ~ +100)



Devices

Buzzer	OFF
	ON
Option Setting	None
	Cutter
	Label Dispenser
	Applicator
Smart Backfeed	OFF
	ON
	4800
	9600
	19200
	38400
	57600
	115200
Serial Port Setting	None
	Odd
	Even
Parity	7
	8
Data Bits	1
	2
Stop Bits	DHCP
	OFF / ON
LAN Setting	IP Address
	0.0.0.0
	Subnet Mask
	255.255.255.0
	Gateway
	192.168.0.254
LCD Setting	Password
	OFF / ON
	Correction
	Year
	Month
	Day
	Hour
	Minute
Clock Setting	Display
	OFF / ON



Printer Control

	Configuration
	Directory
	IPH Testing
	Dump Mode
Test	Sample Pattern
	Self-Test page / Balance
	Select Memory
	Internal / External
	Label Format
	Graphic
	Clear Memory
	Bitmap Fonts
	Ture Type Fonts
	Asian Fonts
	ALL
	Calibration
	Reset to Default



Wizard

	Darkness
	0-19
	Speed
	2-3
	Label with Gaps
	Label with Marks
	Continuous
Media Type	X-Offset
	-100 ~ +100
	Y-Offset
	-100 ~ +100

LCD Operation

When Barcode Printer is Ready, the LCD will display "Ready"
And then the printer is ready to print

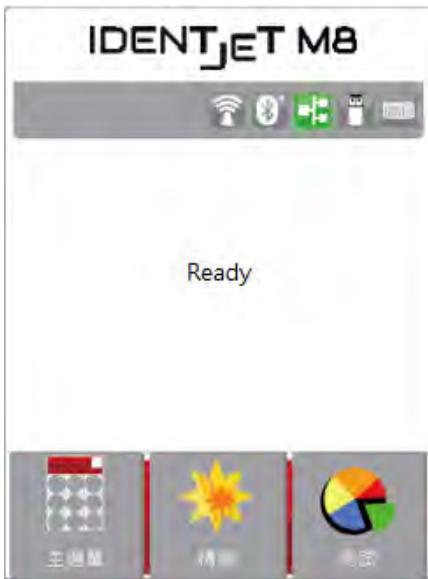

If there is any error occur, there will be Error Message shows on the LCD. You could do the trouble shooting according to or contact with the agent.

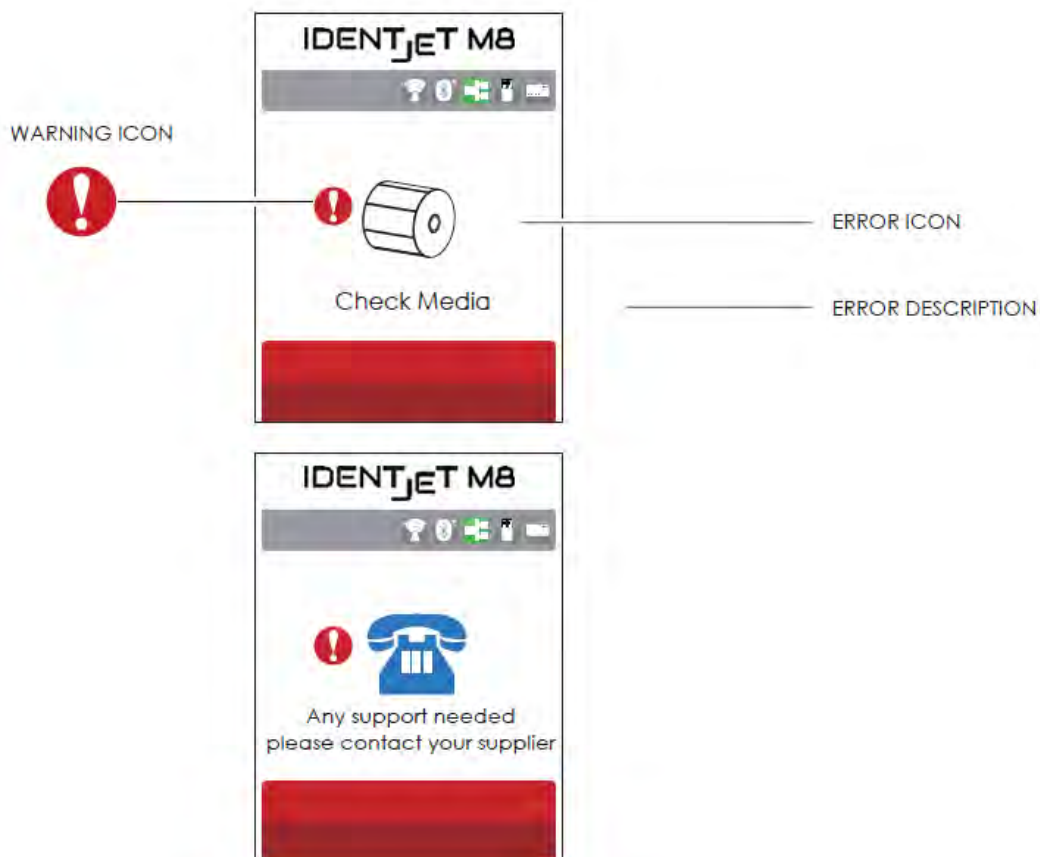

3-4 Label size calibration and Self Test Page

The printer can automatically detect and store label height. That means the host computer does not need to transmit the label height to the printer. And the self-test function lets you check whether the printer is functioning normally. Here is how you run the label size calibration and self test.

- Step.01** ➔ Check that the label stock is loaded correctly.
- Step.02** ➔ Switch off the printer.
- Step.03** ➔ Switch the printer on again, keeping the FEED button pressed. When the READY LED starts to flash red and the STATUS LED lights up orange, release the FEED button. The printer will now measure the label stock and store the label height
- Step.04** ➔ Once the printer has successfully measured the label stock, it will print a self-test label.

The contents of a self-test printout are listed below.
 (The data below is for reference only, actual result may vary according to each situation.)

Printer Model and Firmwave info	IDENTjet M8 1.USX
USB Port Setting	USB S/N:12345678
Serial Port Setting	Serial port:96,N,8,1
MAC Address Info	MAC Addr:xx-xx-xx-xx-xx-xx
DHCP Enable or Unable	DHCP Enable
Ethernet IP Setting	IP xxx.xxx.xxx.xxx
Gateway Setting	Gateway xxx.xxx.xxx.xxx
Sub-Mask Setting	Sub-Mask xxx.xxx.xxx.xxx
Card Status	Card Status:HW Unable to detect any card
Network Status	Network: Cable Not Plug
	#####
DRAM info	1 DRAM installed
Imabe Buffer Size	Image buffer size:1500 KB
Forms storage info	0000 FORM(S) IN MEMORY
Graphics storage info	0000 GRAPHIC(S) IN MEMORY
Fonts storage info	000 FONT(S) IN MEMORY
Asian fonts storage info	000 ASIAN FONT(S) IN MEMORY
Database Storage info	000 DATABASE(S) IN MEMORY
TTF storage info	000 TTF(S) IN MEMORY
Memory Size	4073 KB FREE MEMORY
Speed, Darkness, Ref. Point, print direction	^S4 ^H8 ^R000 ~R200
Media width,length, gap setting info	^W102 ^Q100,3 ^E18
Options setting info	Option:^D0 ^O0 ^AD
Reflective Detecting Info	Reflective AD:1.96 2.84 2.49[0.88_23]
Code Page Setting	Code Page:850

Auto-Calibration

「 Calibration key (C-Button) 」 You could press the calibration key while media been replaced or media error to adjust the media size.

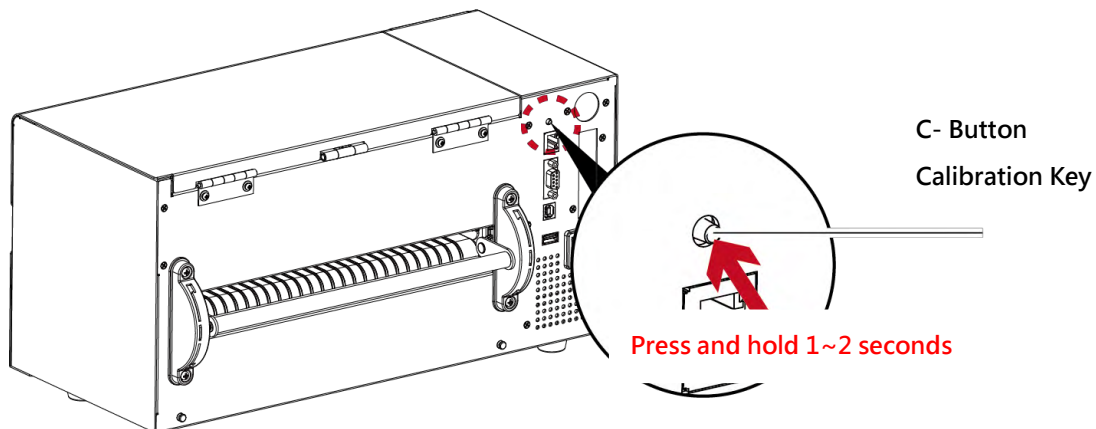

Press and hold the 「 C-Button 」 around 2 seconds, the printer will run the media calibration

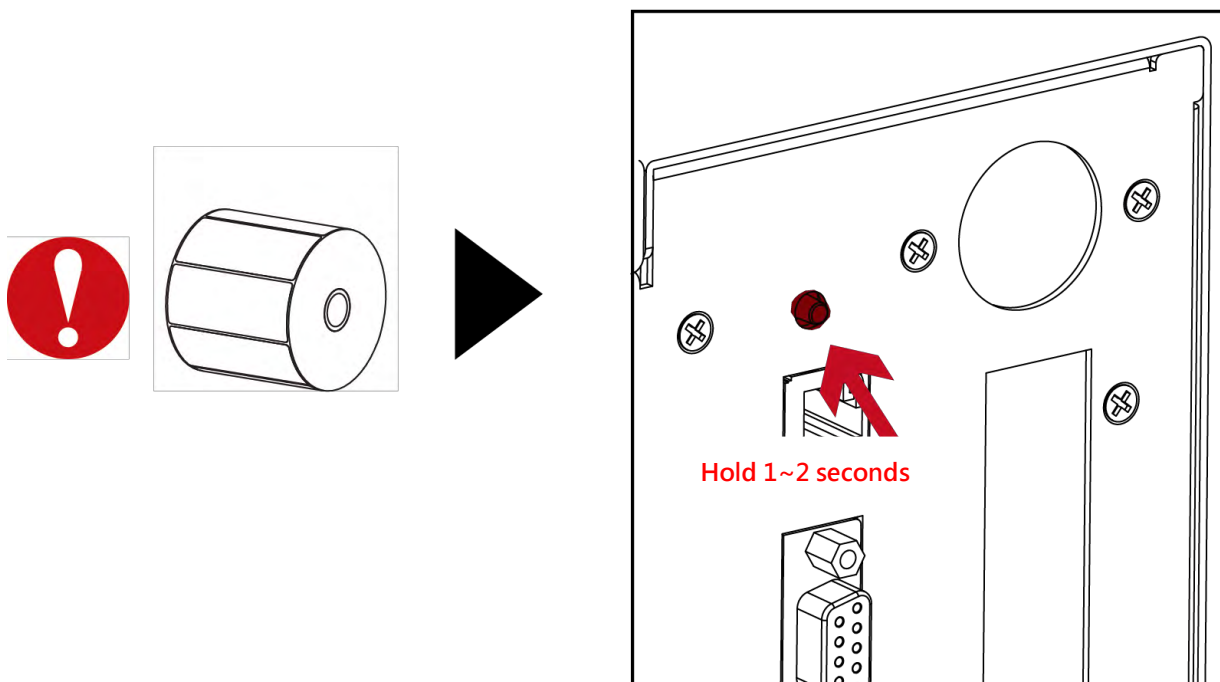

Note

* The "C-Button" function is same as sending command (~S,SENSOR), if run during the printing, the (Print Job) will be deleted and run media calibration. Need to resend the print job after calibration.

3-5 Error Message

If there is any error occurred during the printing, LCD will display the Error message and also buzzer as warning.

Please refer to below for the error status.

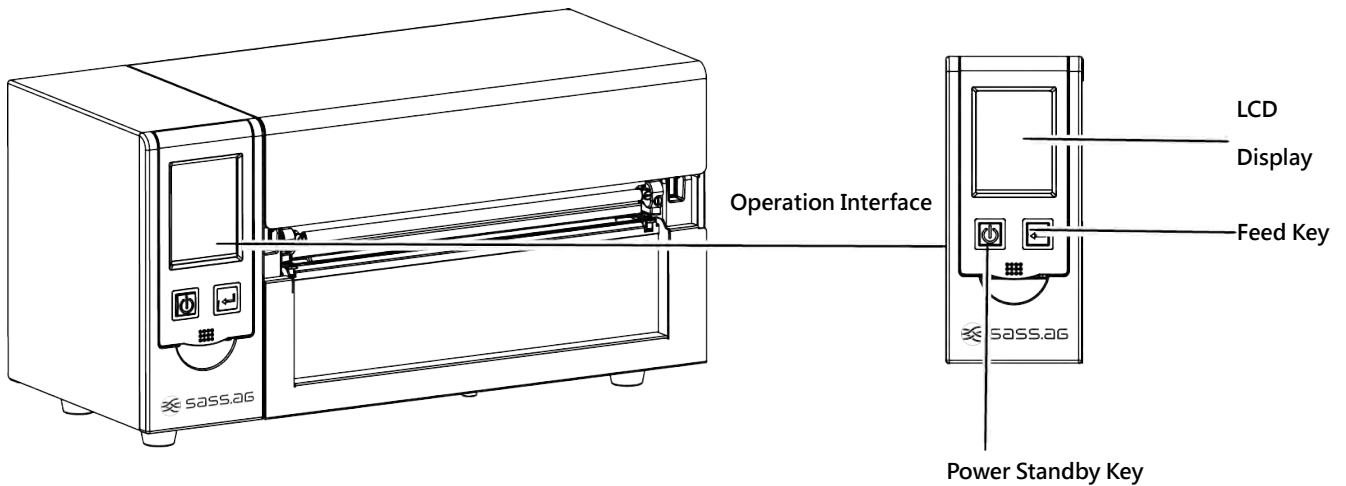

Operation Panel Status

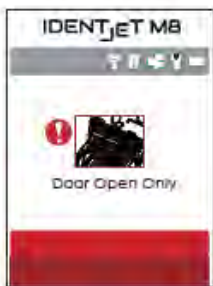

Type	Beeps	Description	Solution
Door Open Only	2 x 4 beeps	The printing mechanism is not correctly closed.	Open the print mechanism and close it again.
TPH Over Heat	None	High temperature at the print head.	Once the print head has cooled down, the printer switches to standby mode.
Media Error	2 x 3 beeps	No ribbon is installed and the printer displays an error.	Make sure that the printer is set to direct thermal printing mode.
		The ribbon is finished or the label supply hub is not moving.	Replace the ribbon roll.

Operation Panel
Status



Status	Beeps	Description	Solution
Media Error	2 x 2 beeps	No paper is detected.	Make sure that the label sensor is positioned correctly. If the sensor still does not detect the paper, run the auto-detection function again.
		Paper is finished.	Replace the label roll.
		Printer feed problem.	Possible reasons: the print medium has become trapped around the rubber roll; the sensor cannot detect a gap or black mark between the labels; there is no paper. Please reset the sensor.

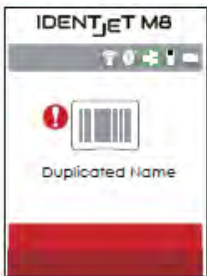
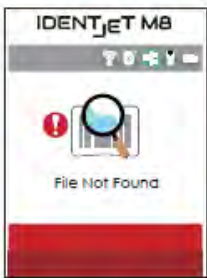
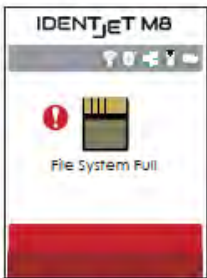

File Error	2 x 2 beeps	The memory is full. The printer prints the message "File System full".	Delete unnecessary data or install additional memory.
		Unable to find file. The printer prints the message "File not found"	Use the "~X4" command to print all files. Then check whether the files exist and whether the names are correct.
		A file of the same name already exists. The printer prints the message "Duplicated Name".	Change the name of the file and try storing it again.

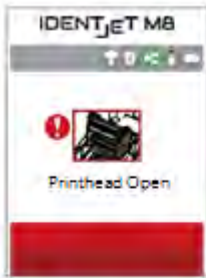

Status	Beeps	Description	Solutions
Printhead Open	2 x 4 Beeps	Printhead Open or Print Frame not locked well	Make sure the print head is locked in position.
TPH Over Heat	N/A	TPH Temperature too high	When TPH is over heated, the printer will stop and wait to cool down and then back to ready status.
Check Ribbon	2 x 3 Beeps	Ribbon not install	Make sure the Printer is in DT mode or not.
		Ribbon out or Ribbon Supply don't move	Replace new ribbon roll

3-6 Connected with USB Devices

Definition : USB Host port supports either device : USB memory stick, USB keyboard or scanner.

Purpose

- USB memory stick : It extends the user memory space for Graphic, Font, Label Format, DBF and Command files downloading. The printer's Firmware also can be updating if copy new version of Firmware into USB memory stick.
- Connecting an USB keyboard to printer for "Keyboard Mode" mode operation.
- Plug-in an USB scanner to operate the printer in "Keyboard Mode" .

Usage of Extended Memory

- USB memory stick : It supports hot-plugging function; printer will create a Folder "\\LABELDIR" and switch "User Flash" to " Extended Memory" automatically while user plugs an USB memory stick into a printer.
- Connect USB with the printer; To connect PC and printer through USB.

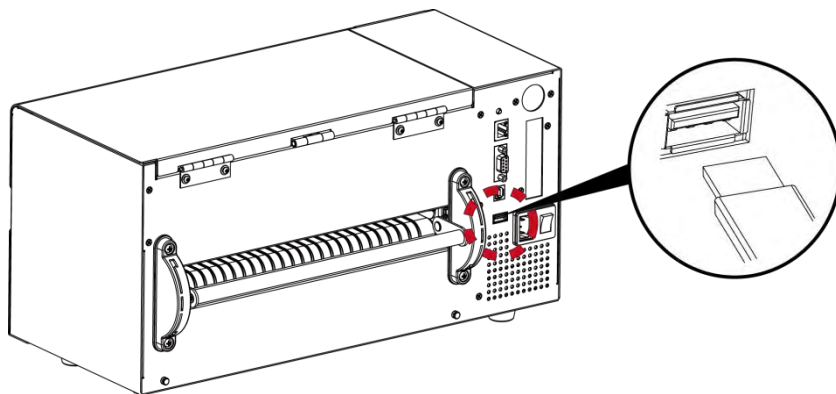

Usage of Firmware Update

- Remove USB memory stick from printer and plug-in it to a PC's USB port.
- Copy a new version of Firmware "xxx.bin" to the Folder "\\LABELDIR\FW"
- Remove USB from PC and plug-in back to the printer. The printer will update the Firmware automatically
- The "\\ LABELDIR \ FW" directory allows only one file exists, if there are multiple files, the files will be confused.
- Don't remove the USB memory stick out while it's under updating with "Flash Writing..." message that displays on LCD panel.

USB Keyboard

- When plug-in an USB keyboard to the printer, LCD touch panel will display "Enter Standalone", press the "Y" key on keyboard to entering "Keyboard Mode" operation. Under this mode can perform "Recall Label", set "Country Code", "Code Page", "Clock Setting", "Database Setting" and "Label Edit".
- Connect a USB keyboard to the printer, if not into the keyboard mode, press the "N" key to leave. Into Standalone mode of operation, to leave the Standalone operation, press "ESC" key to exit.
- After leaving the keyboard mode, for re-entry, press the keyboard "F1" key or reboot, you can follow the steps in the first step choose whether or not (Y / N) into the keyboard mode.

Scanner

- When plug-in an USB scanner to the printer, LCD touch panel will display "Enter Standalone", tap the "Feed" Key to entering "Keyboard Mode" operation.

Note

- * The USB Host port on printer is not support "USB HUB" function.
- * The USB Memory Stick supports with "FAT32" Disk Format and up to 32GB only. The certified venders are Transcend, Apacer, ADATA, Patriot, Consair and Kingston.
- * The USB Memory Stick only supports download through the printer, On a PC, user may copy entire folder "\LABELDIR" from USB memory stick to PC or vice-versa. Can not copy the data to USB Memory Stick via PC individually.
- * External USB Host port is for power 500mA, is not recommended as electronics charging use.

4. Installing the IdentSET software

The IdentSET software is used to manage the network configurations when connecting the printer via Ethernet port. It is available on product CD or can be downloaded from official website. To install the IdentSET, please follow below steps.

Step.01 ➔ Insert the product CD in the CD/DVD drive, and click "OTHER CHOICES" button.

Step.02 ➔ Select "ETHERNET".

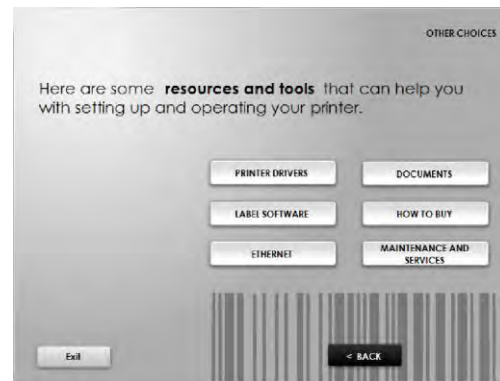
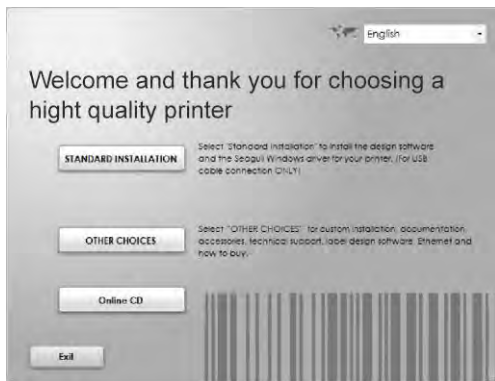

Step.03 ➔ Click "Install Ethernet IdentSET Software", installation screen as right diagram, click "Next".

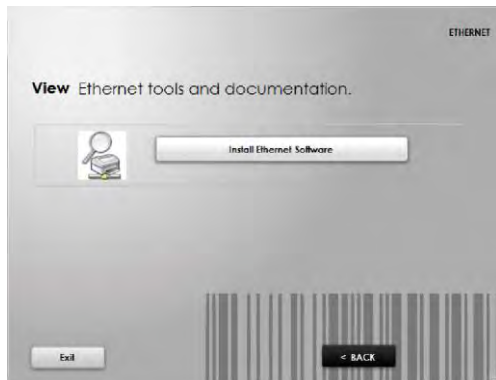

Step.04 ➔ Specify the "Installation Folder", then click "Next" to installing.

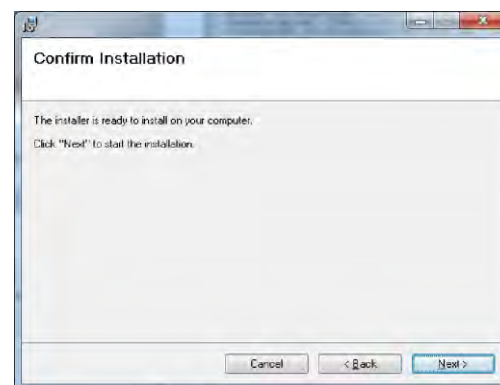
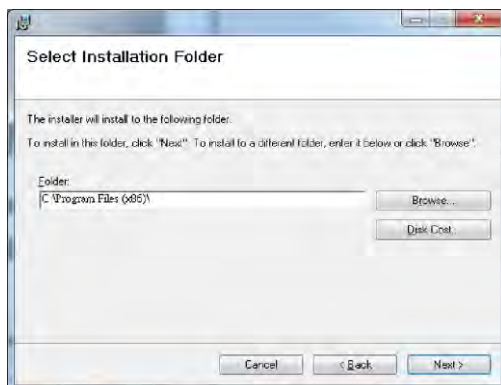

Step.05 ➔ Once the installation is completed, you will see the IdentSET icon on your desktop as right diagram.

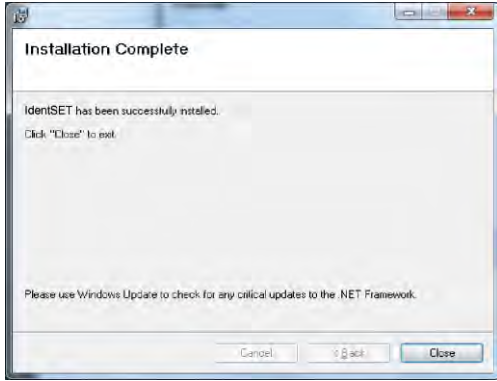

4-2 The Interface of IdentSET

Your printer can also be used through a network connection (as a remote network printer), make sure the printer connected to the Internet and the power cord, you can use the Interface of IdentSET to search connected network printers.

Step.01 ➔ Click the IdentSET icon to start the program, you will see the start page as left diagram. Click the magnifier icon to search the printers which are connected via Ethernet port in you network environment (as right diagram).

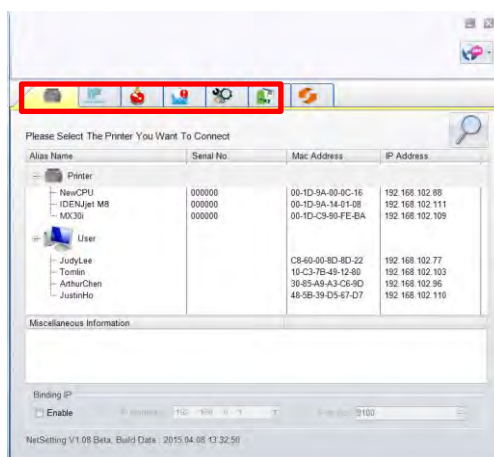
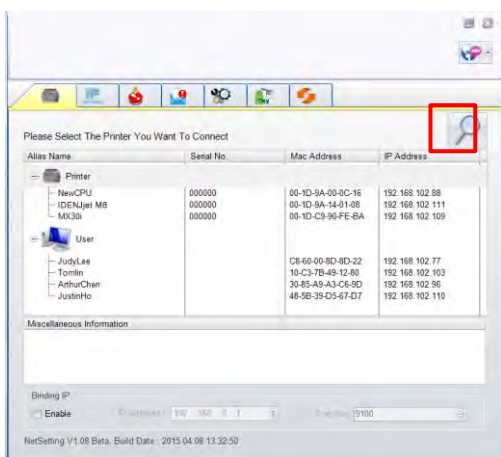

Step.02 ➔ There are six tabs on the top of interface which can configure different types of network settings. But for the data security reason, you need correct password to enter the configuration pages.

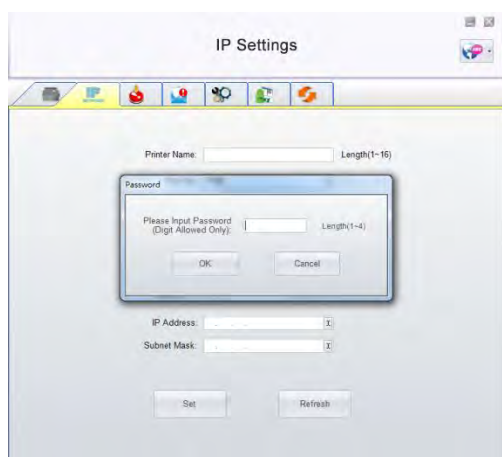

NOTE

* The default password is "1111", you can change the password later from the "IP Setting" tab.

IP Setting

The IP Setting tab can change the printer name, Port number, Gateway setting and the password for configuring the printer. You can also set the printer's IP address either by DHCP or by Static IP.

IP Settings

Printer Name: IDENJet M8 Length(1-16)

Port No: 9100

Default Gateway: 192.168.102.254

Password: 1111 Length(1-4)

Get IP From DHCP Server

Static IP

IP Address: 192.168.102.111

Subnet Mask: 255.255.255.0

Set Refresh

You can press "Set" button to apply the settings and "Refresh" button to refresh the setting values.

NOTE

* To fully benefit from the IdentSET software, you should be familiar with basic networking principles. Please contact your network administrator for related network setting information.

* When enabling DHCP, if you find the IP Address as: IP = 169.254.229.88, Net mask = 255.255.0.0, Gateway = invariable (last value), the IP Address is invalid.

Alert Path Setting

NetSetting will send the alert messages to designated mail account when the error happened on printer. The alert messages are sent by SMTP (Simple Mail Transfer Protocol) or SNMP (Simple Network Management Protocol). You can set or change the configurations of SMTP and SNMP on this "Alert Path Setting" tab.

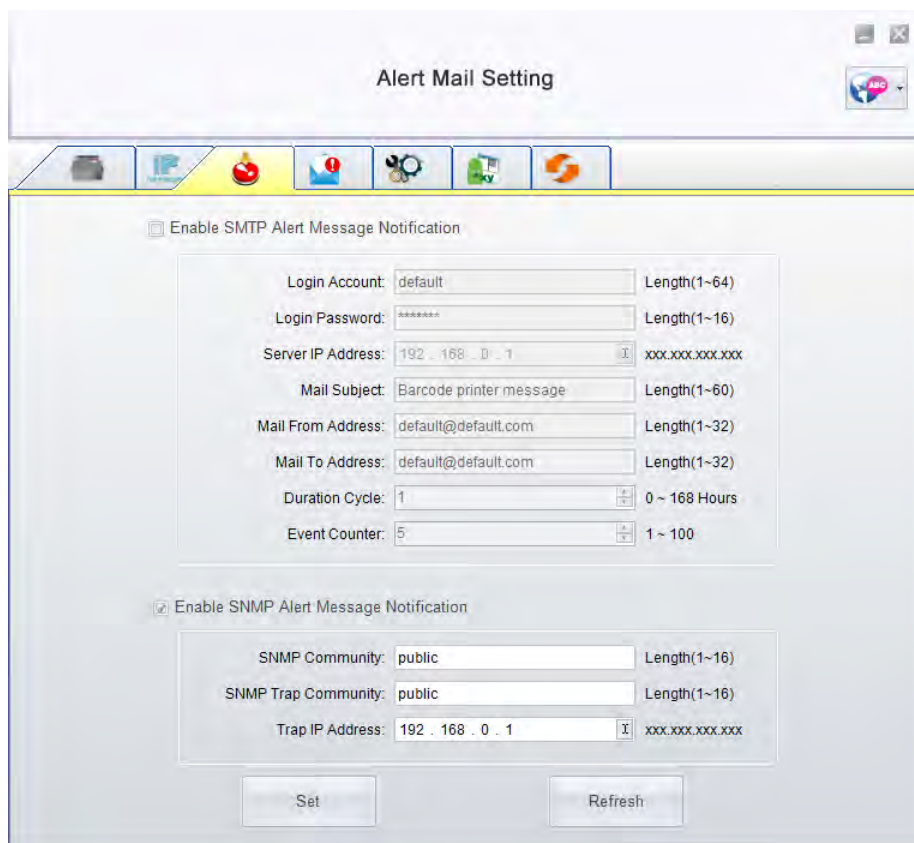

The screenshot shows a window titled "Alert Mail Setting" with a toolbar at the top containing icons for printer, mail, alert, settings, and other functions. The main content area is divided into two sections:

- Enable SMTP Alert Message Notification** (checkbox checked):
 - Login Account: default (Length(1~64))
 - Login Password: ***** (Length(1~16))
 - Server IP Address: 192 . 168 . 0 . 1 (Length(1~16), format xxx.xxx.xxx.xxx)
 - Mail Subject: Barcode printer message (Length(1~60))
 - Mail From Address: default@default.com (Length(1~32))
 - Mail To Address: default@default.com (Length(1~32))
 - Duration Cycle: 1 (0 ~ 168 Hours)
 - Event Counter: 5 (1 ~ 100)
- Enable SNMP Alert Message Notification** (checkbox checked):
 - SNMP Community: public (Length(1~16))
 - SNMP Trap Community: public (Length(1~16))
 - Trap IP Address: 192 . 168 . 0 . 1 (Length(1~16), format xxx.xxx.xxx.xxx)

At the bottom of the window, there are two buttons: "Set" and "Refresh".

You can press "Set" button to apply the settings and "Refresh" button to refresh the setting values.

Alert Message Setting

For the alert message notification function, you can decide which error cases need to be sent out to the operator. Moreover, the alert messages can be set to be sent by SMTP, SNMP or both.

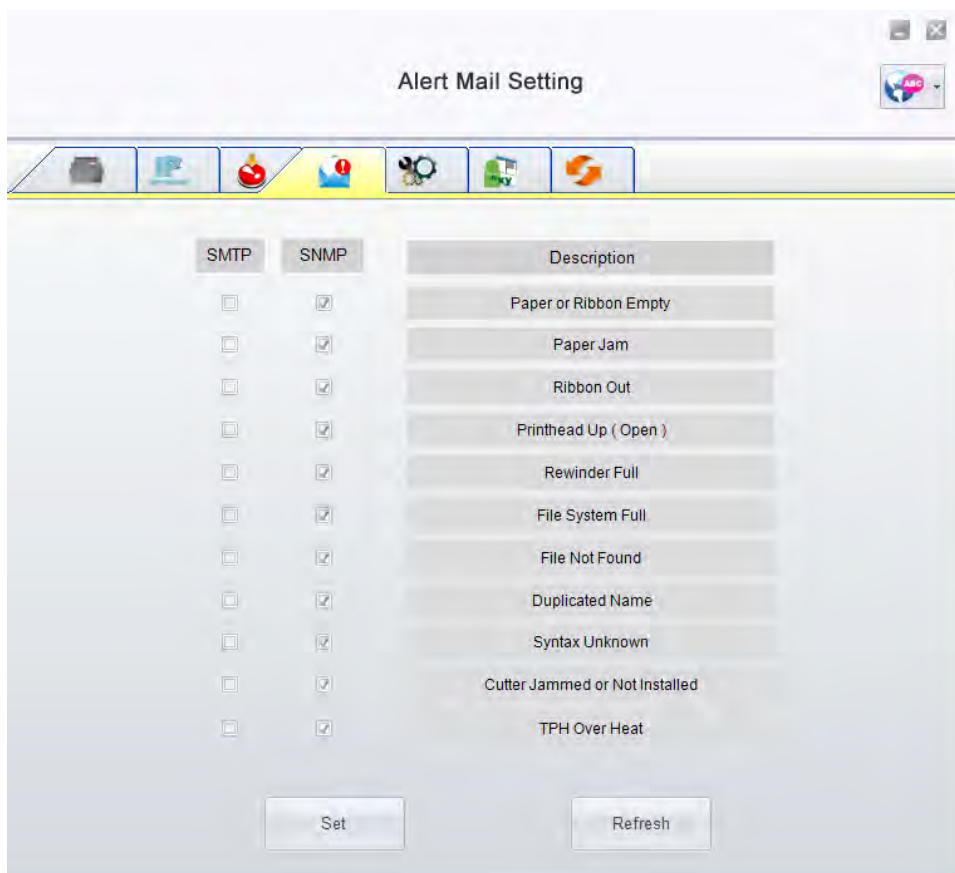

You can press "Set" button to apply the settings and "Refresh" button to refresh the setting values.

Printer Configuration

Set or change the configurations of connected printer. Most of key settings for the printer operation can be done by this setting page.

The screenshot shows a software window titled "Alert Mail Setting". At the top, there are several icons representing different printer models. The main content area is divided into two sections: "Printer Setup" and "Miscellaneous".

Printer Setup

Printer Model	Tear-off Position	Speed	Darkness
IDENJet M8	12	2	5
Dispenser/Applicator	Labels per Cut	Printing Mode	
0 (None)	0	Direct Thermal	

Serial Port Setting

Baud Rate	Parity	Data Bits	Stop Bits
9600	None	8	1

Miscellaneous

LCD Language	Sensing Mode
	2 - Automatic
Keyboard Country Code	Pre-Printing
	OFF
Code Page	Top Of Form
Code Page 850	2 - OFF while Power On
Buzzer	
OFF	

At the bottom of the dialog, there are two buttons: "Set" and "Refresh".

You can press "Set" button to apply the settings and "Refresh" button to refresh the setting values.

User Command

The "User Command" tab provides a communication interface for operator to control the printer. Input printer commands in "Input Command" window and press "Send Command" button, the commands will be sent to the printer. For some commands that will return response message, the message will be displayed in "Output Message" window.

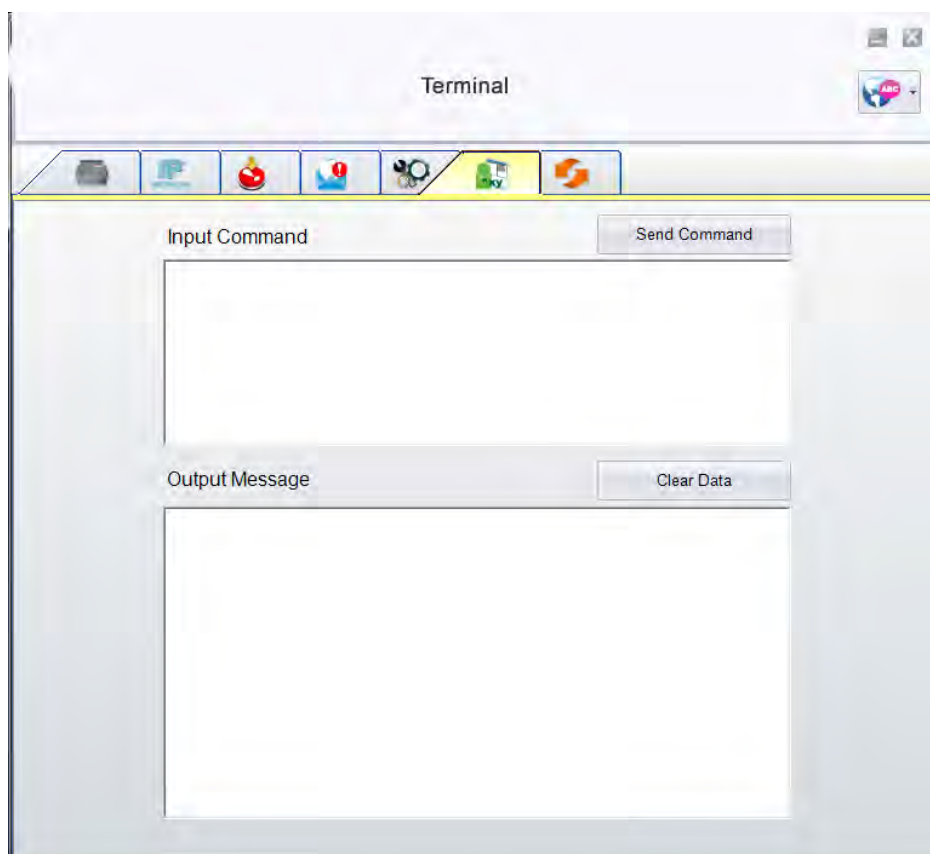

You can press "Set" button to apply the settings and "Refresh" button to refresh the setting values.

Firmware Download

On “Firmware Download” tab, the current version of printer firmware will be showed on the screen. If you need to update the printer firmware, just specify the file location of firmware file and press “Start Download Firmware” button. The printer firmware then can be updated remotely.

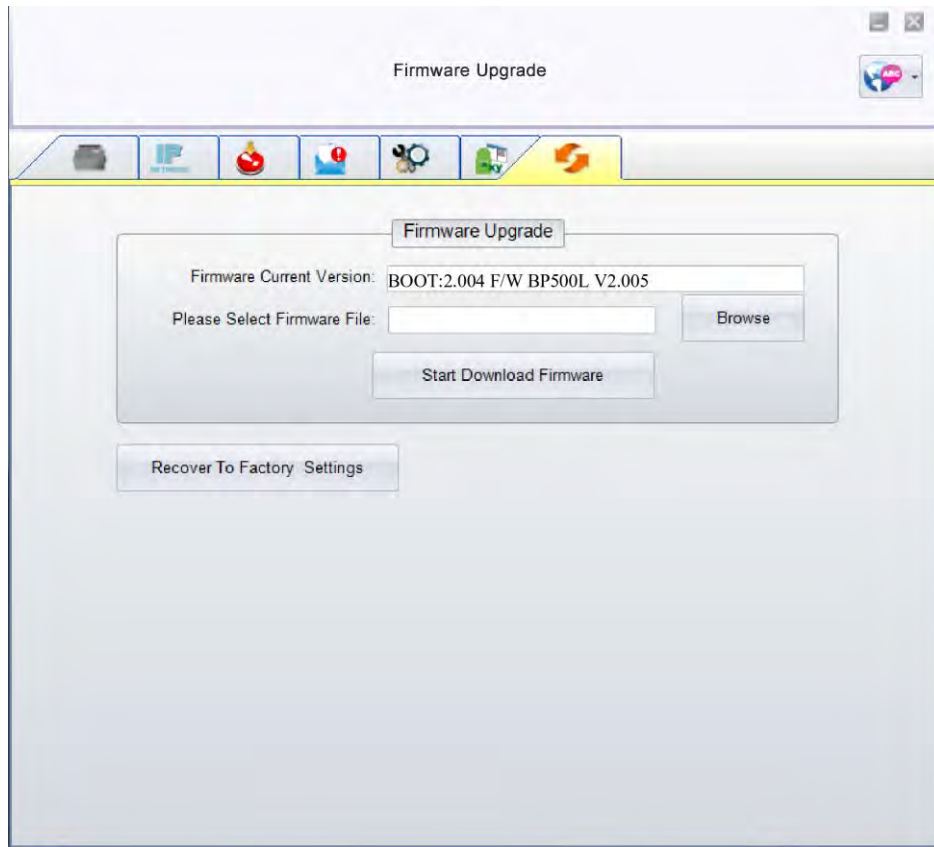

In addition to the firmware update, you can press “Recover To Factory Settings” button to restore the printer configurations back to factory default.

5 Barcode Printer Options

5-1 Pre -step for Options Installation

Before install the options, please follow the pre-Step 1st.

1. **Power off Barcode Printer**
(Please must be turn off the power before any options installation)
2. **Open the Top Cover**

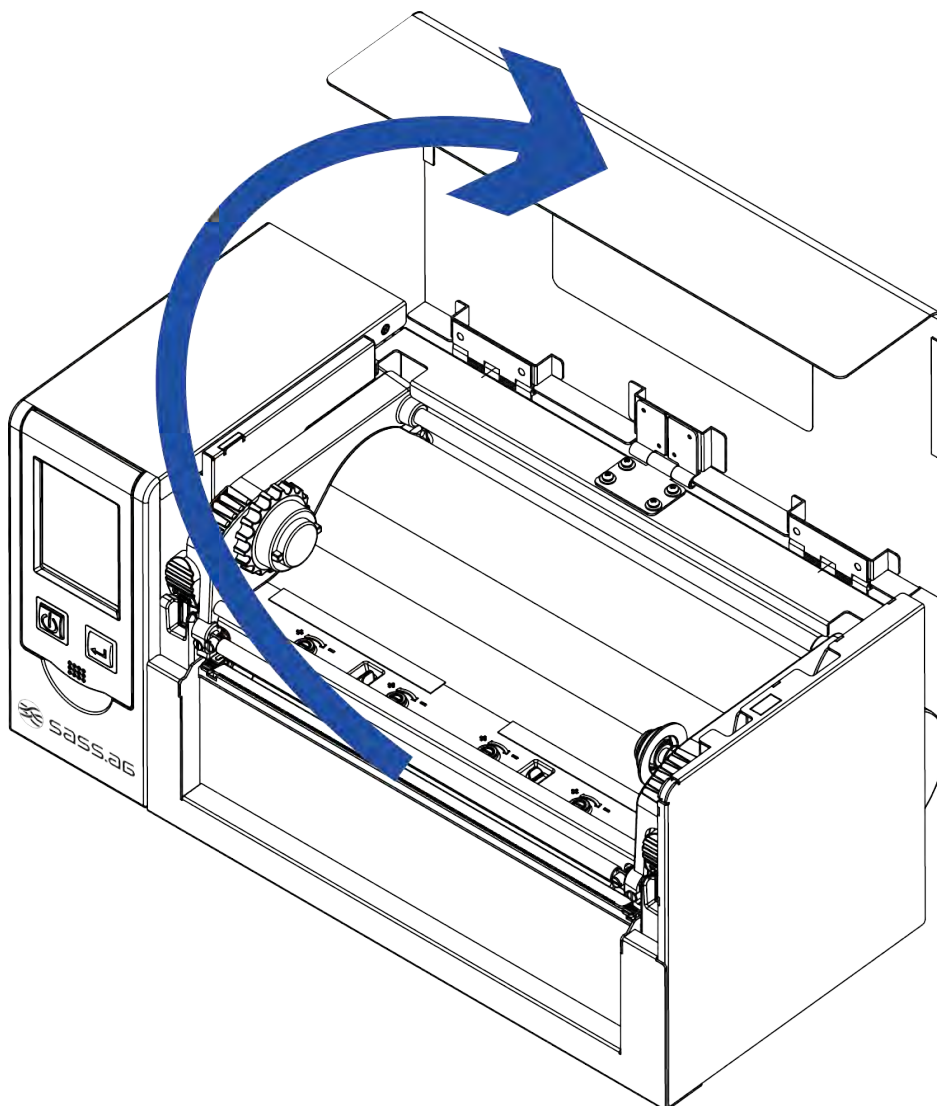

Note

- * Make sure the printer is power off status before cutter installation.
- ** The linerless media is not suitable for this option cutter.

5-2 Cutter Installation

Cutter parts introduction

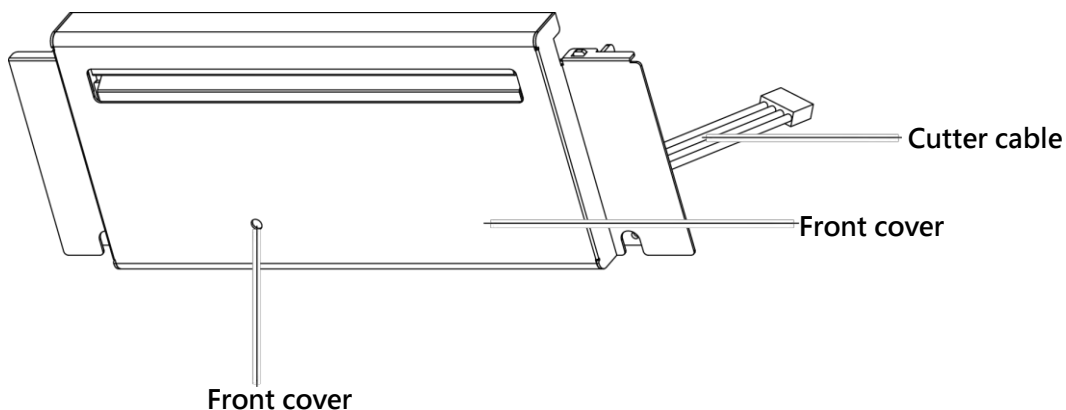

Cutter Module Installation Steps:

(Following Steps must be under printer power off condition)

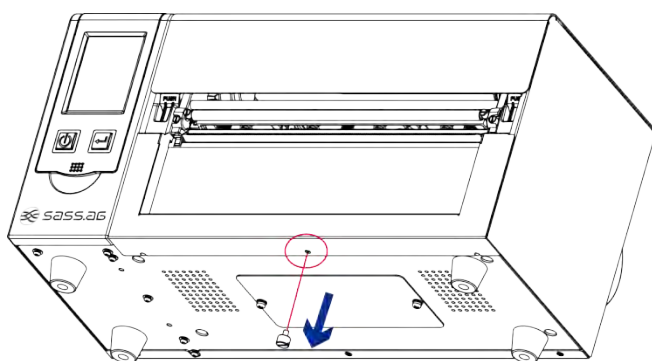

Step 1. Disassemble the bottom case screws (Marked in Red circle)

Note

- * Before cutter installation, make sure the printer is under power off condition or the power cord is not plugged !
- ** The linerless media is not available supported.
- *** The maximum cutting width is 230 mm · the minimum cutting height is 30 mm above. (If over the range then it's not under warranty condition)
- **** Suggested Stop Position for Cutter is (^E) 29~30 °

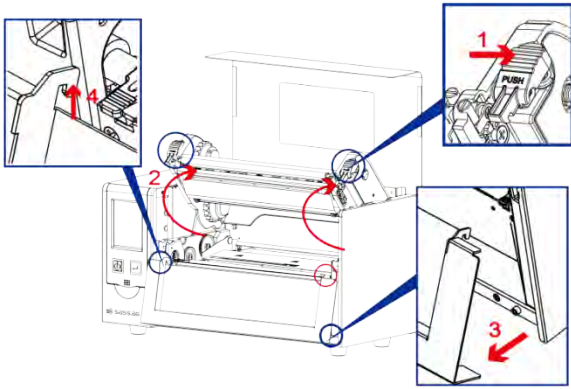

Step 2.

(No. 1) Release the TPH lock

(No. 2) Follow the direction to open the print frame.

(No. 3 and 4) Take off the front panel

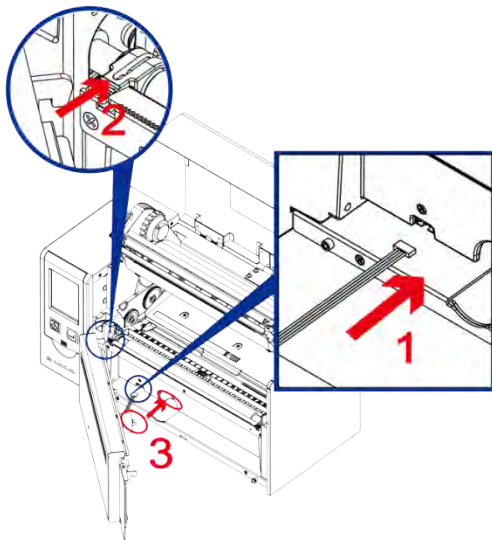

Step 3.

(No. 1) Connecting the cutter cable into printer

(No. 2) Hook the Cutter module into position.

(No. 3) Follow the direction to put the cutter motor into position (mark in red circle)

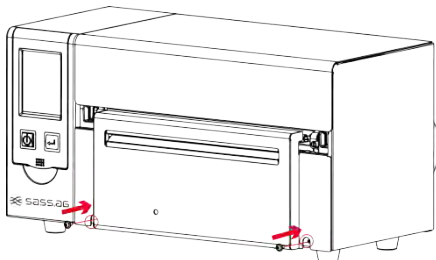

Step 4. Fasten the screw in position.

Assembly completely show as below

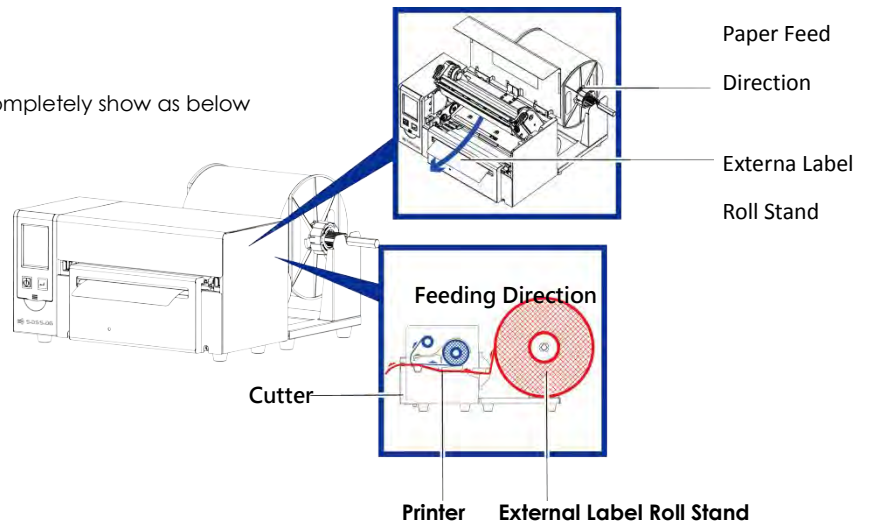

Note

* Please must make sure the power is off status before any installation for the security purpose.

5-3 Wi-Fi Module Installation

Step 1. Remove the rear plate

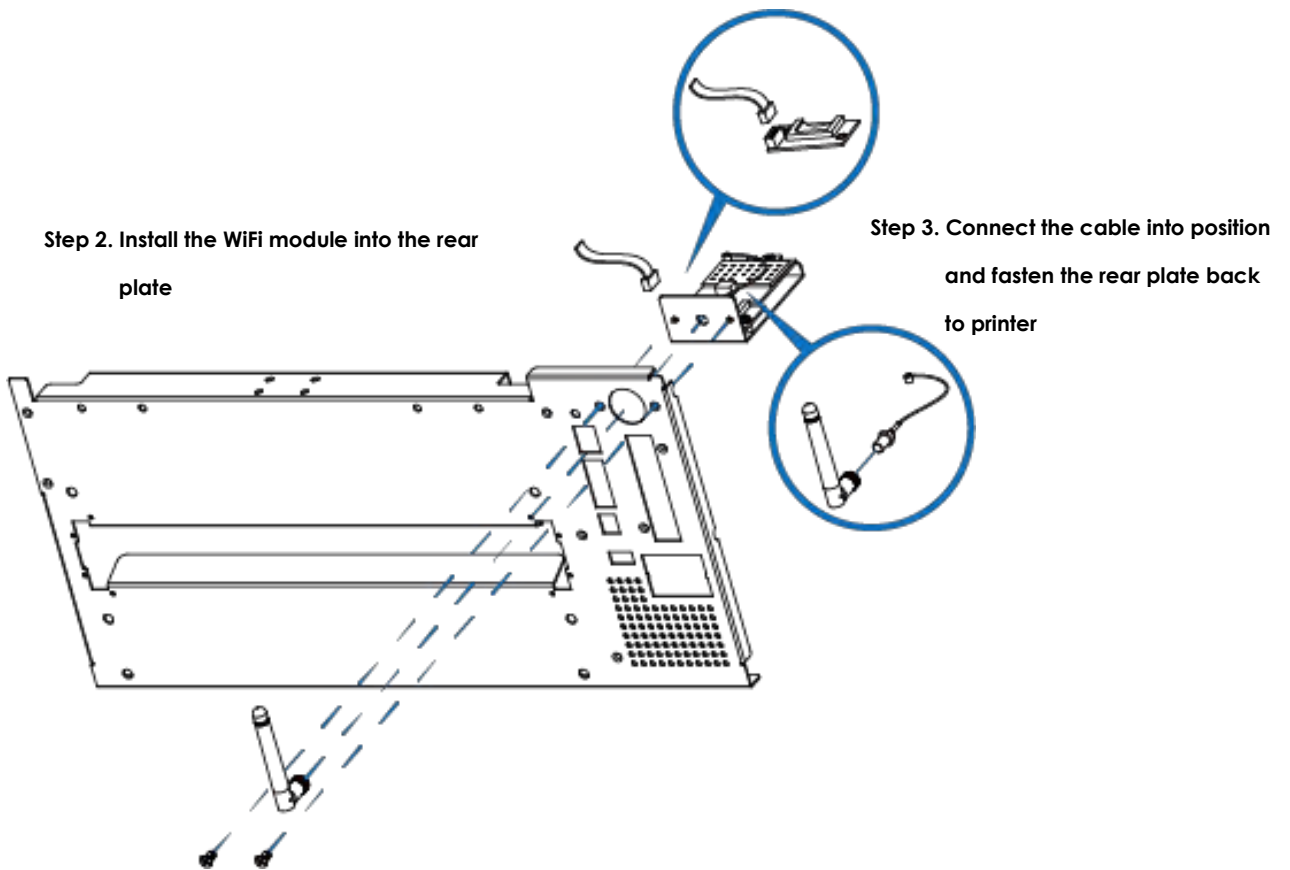

* Wi-Fi module

5-4 Bluetooth & Parallel port adaptor module

Step 1. Remove the rear plate

Step 2. Install the Bluetooth module into the rear plate

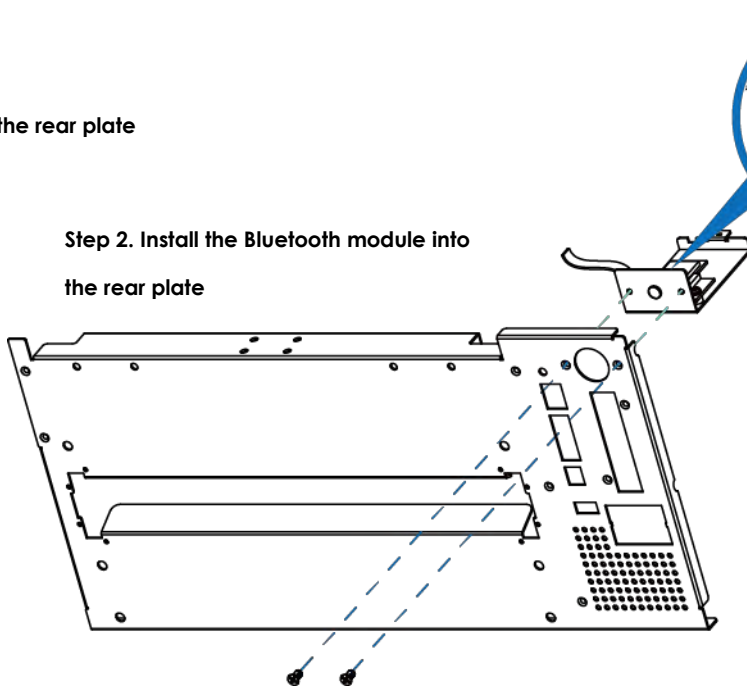

Step 3. Connect the cable into position and fasten the rear plate back to printer

Step 1. Remove the rear plate

Step 2. Install the Parallel port adaptor module into the rear plate

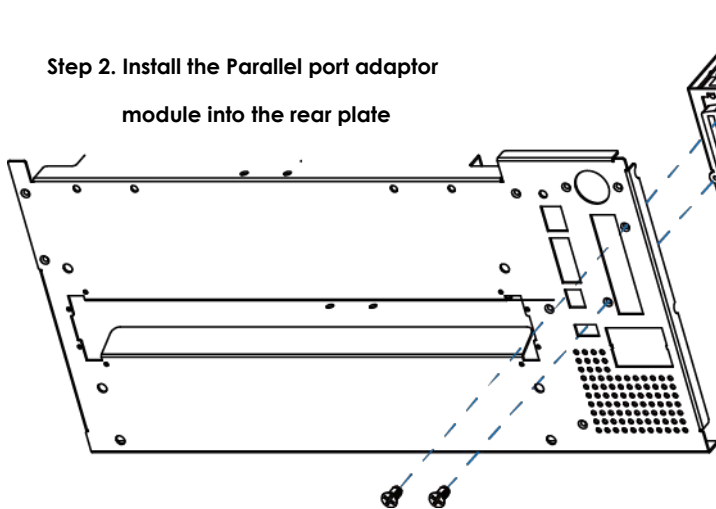

Step 3. Connect the cable into position and fasten the rear plate back to printer

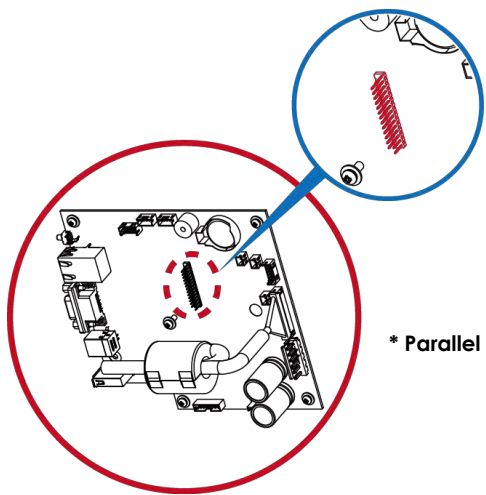

* Parallel port cable connector position

6 Maintenance and Adjustment

6-1 Print Head Replacement

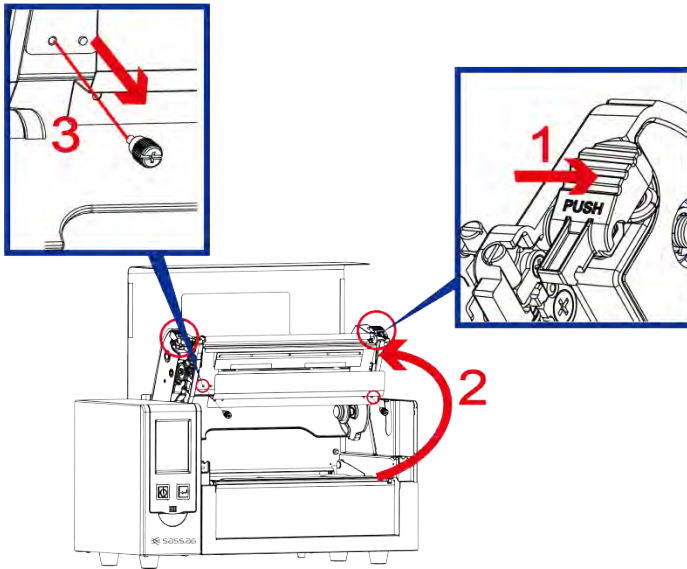

Step 1.

(No. 1) Release the TPH lock.

(No. 2) Follow the direction to open the Print frame.

(No. 3) Remove the TPH cover screws.

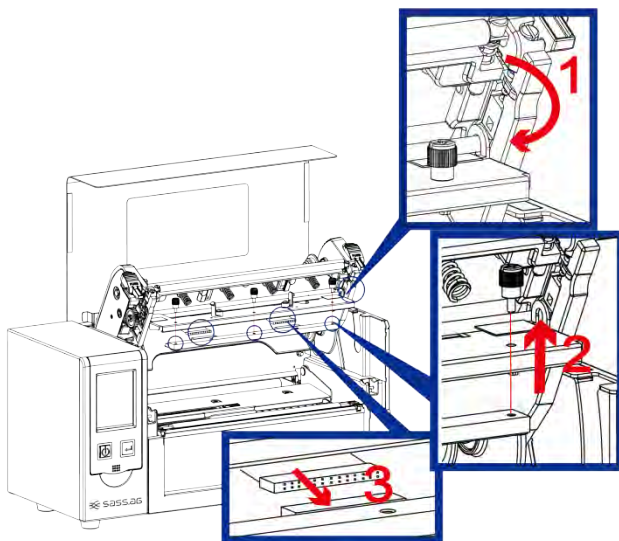

Step 2.

(No. 1) Follow the direction to roll down the TPH module.

(No. 2) Follow the direction to take out the thumb screws

(No. 3) Take off the TPH module from the connector.

Note

* Make sure the printer is power off status before TPH replacement.

6-2 Print Line Adjustment

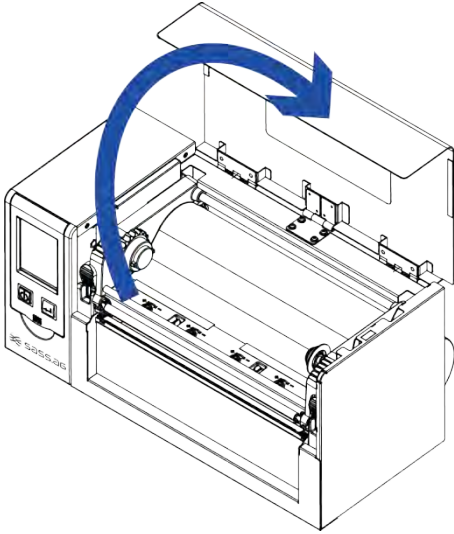

1. Lift up the top cover.

2. Use the flat screw driver

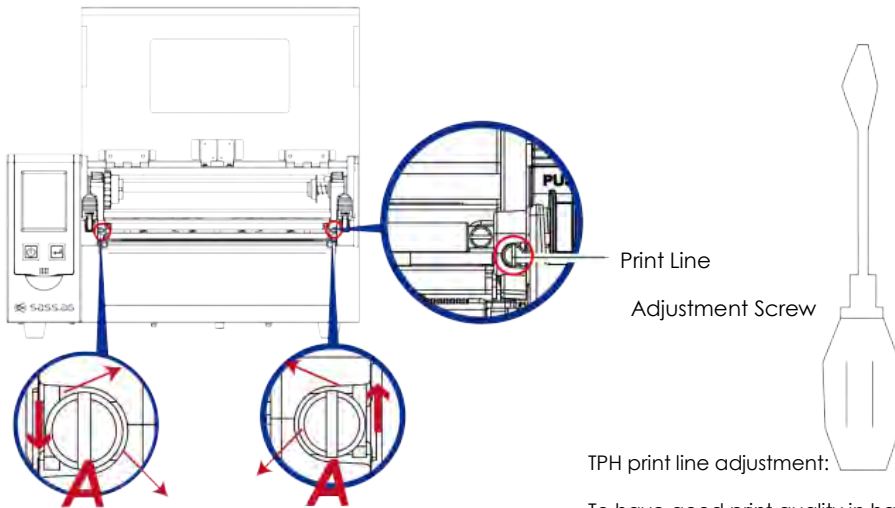

TPH print line adjustment:

To have good print quality in hardness or thicker media, we will suggest to move the print line a little bit forward (paper feeding direction) . And it will be able to apply the flat screw driver(as above figure) turn in clockwise or counter clockwise to rotate the screws (A) to move back or forward the TPH position. The adjustment screw (A) of the left and right side of the print head position adjustment should be adjusted so that the print line is parallel to the center line of the roller. Adjust the screw (A) to rotate one turn, the print head displacement stroke is 0.5mm, it is recommended to adjust the way progressive, each time to adjust the 1/4 turn to confirm the print quality situation.

Print line Adjust

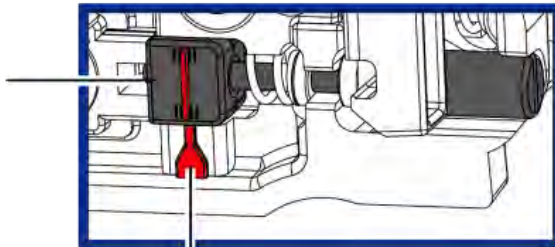

Indication Line

(A) Turn the adjustment screw (A) on the left and right sides to the position where the adjustment line is aligned with the indicating line, and return to the original position and then adjust it again according to the above adjustment method.

6-3 Ribbon Tension Adjustment

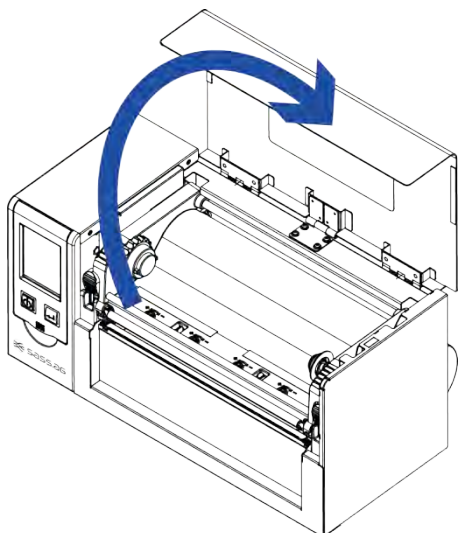

1. Lift up the top cover

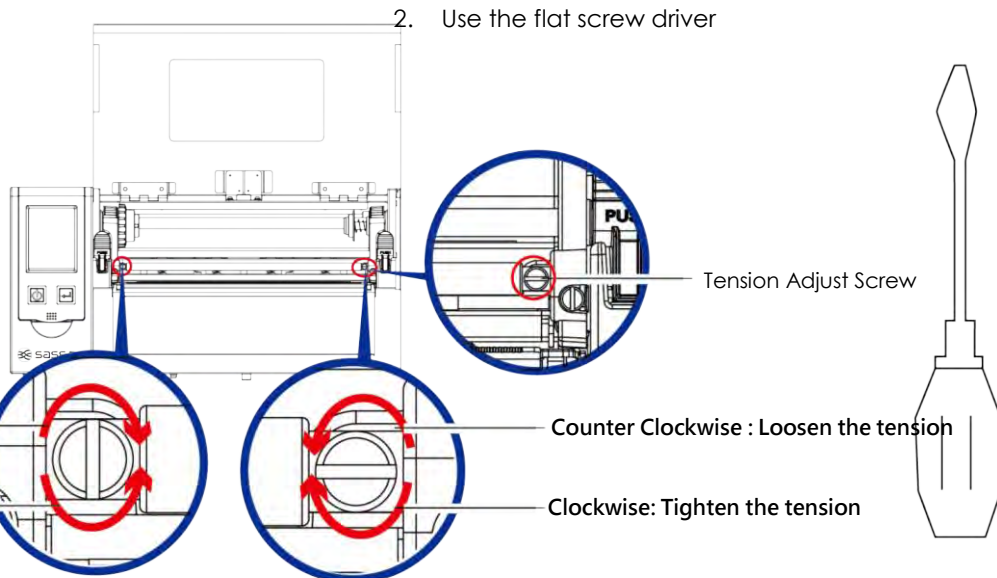

6-4 Print Head Cleaning

Dirt on the print head or ribbon, or glue residue from the label stock may result in inadequate print quality. The printer cover must therefore always be closed during printing. Keeping dirt and dust away from the paper or labels ensures a good print quality and a longer lifespan of the print head. °

Print Head Cleaning Steps

- Step.01 Switch off the printer.
- Step.02 Open the printer cover.
- Step.03 Release the printing mechanism and lift it.
- Step.04 Remove the ribbon
- Step.05 To remove any label residue or other dirt from the print head (see red arrow), please use a soft lint-free cloth dipped in alcohol

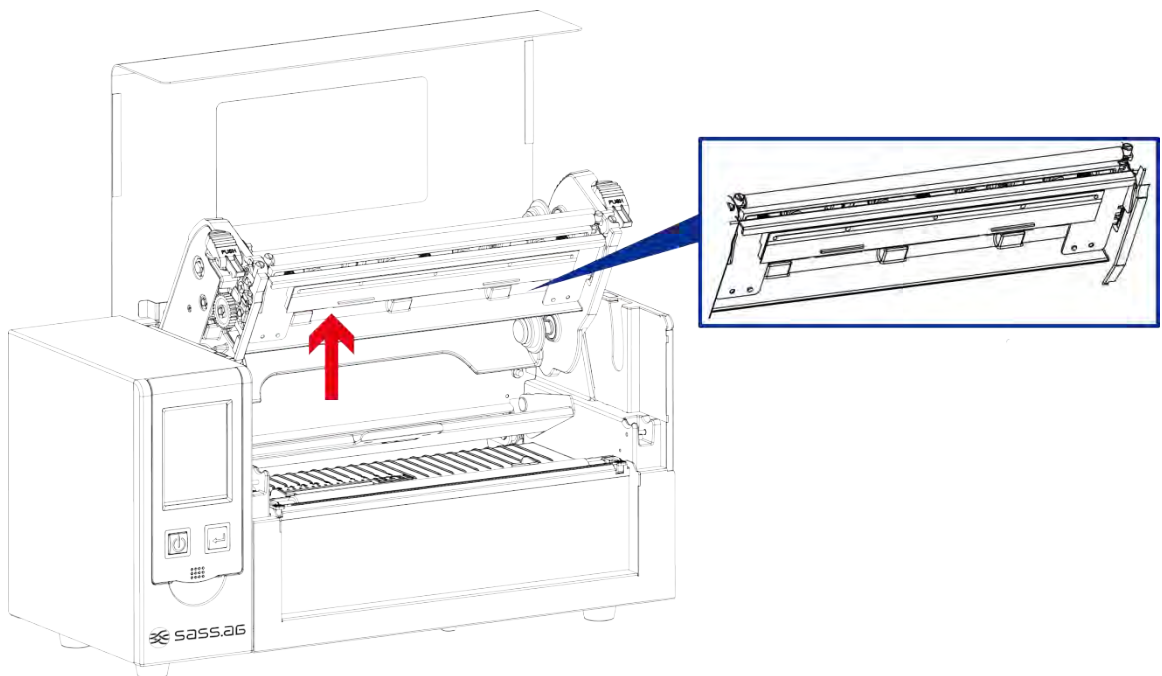

Note

- * The print head should be cleaned once a week.
- ** Please make sure that there are no metal fragments or other hard particles on the soft cloth used to clean the print head.

6-5 Print Head Pressure Adjustment

When printing on special media (with varying material thickness), the print quality may suffer. You will then need to adjust the print head pressure.

Adjustment Steps

Step.01 ➡ Open the printer cover.

Step.02 ➡ Remove the ribbon.

Step.03 ➡ Use a screw driver and slowly turn the adjustment screws for the print head to increase or reduce the print head pressure. Do not screw it hard, otherwise the machine will be broken.

Step.04 ➡ Turn the adjustment screws according to actual position which is unsuccessful printed. Turn towards + (Plus) indicates : The pressure is increased ; Turn towards – (Minus) indicates: The pressure is reduced.

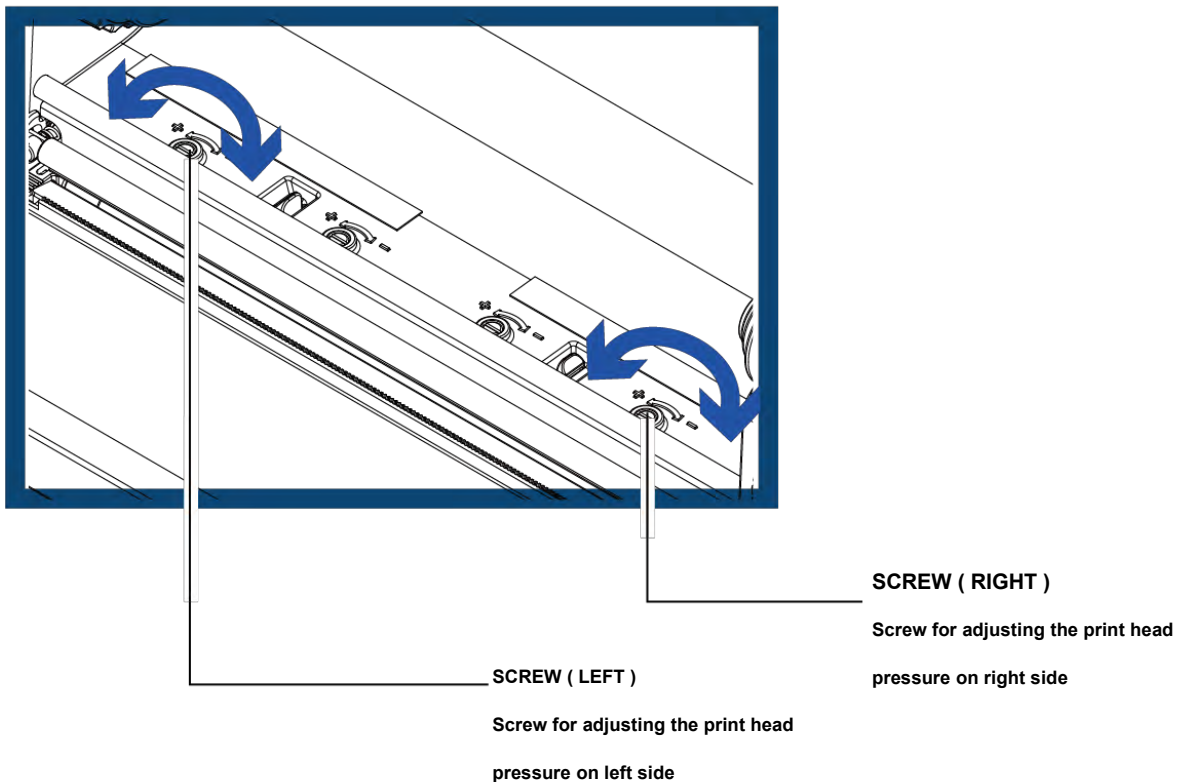

6-6 Ribbon Wrinkle Adjustment

The use of different ribbon materials may cause wrinkling of the ribbon, which in turn affects the print result as illustrated by the examples in (a) and (b). To change the print result, you can adjust the ribbon shield screws. If your print result looks like the example in (a), you need to turn



To keep track of the change in print quality, you should adjust the screws by half a turn at a time. Print a test page. If there is no improvement in the print result, turn the screw by another half turn. Do not turn the adjustment screw more than two full turns.

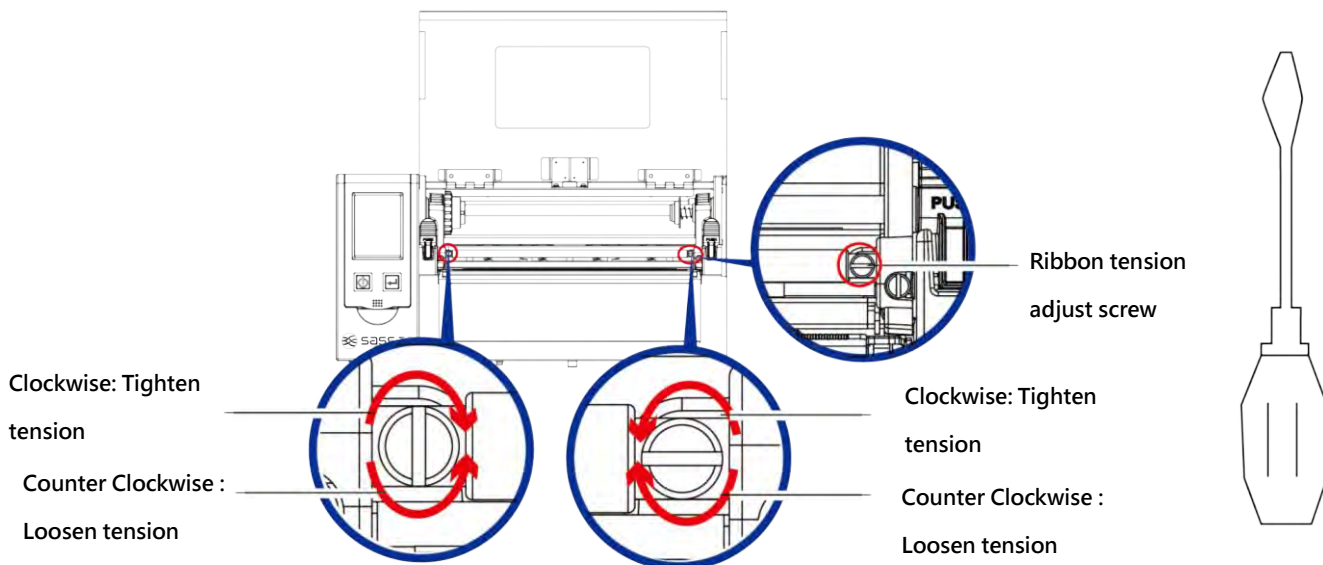

Note

* If you adjust the screw by more than two full turns, the paper feed may no longer function correctly. In that case, unscrew the ribbon shield screws fully and restart the adjustment process.

6-7 Cutter Error Trouble Shooting

While using the cutter, paper jams may occur. Please follow the below steps to clean the paper jam. A socket head screw for adjusting the cutter is located on the bottom of cutter module, as shown in below illustration.

Guillotine Cutter

➤ Cleaning Steps

Step.01 ➔ Switch off the printer.

Step.02 ➔ Use a Philips screwdriver to turn the socket head screw and release the knife.

Step.03 ➔ When you have cleared the paper jam, switch on the printer again. The cutter will automatically reset.

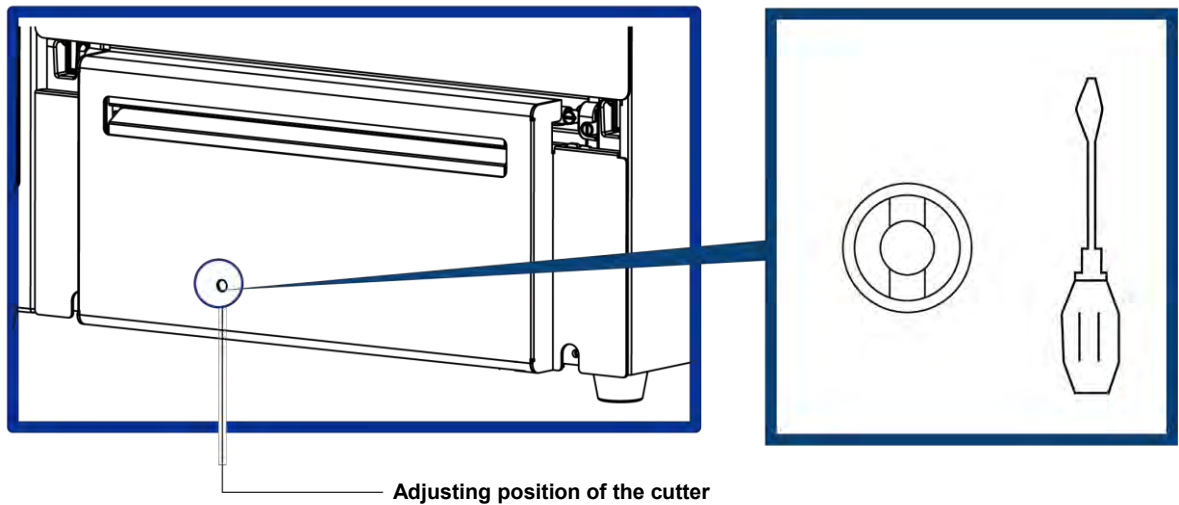

Note

* Make sure power is off status before repairing.

** Labels should be at least 30 mm high to ensure correct functioning of the cutter ◦

6-8 Trouble Shooting

Problem	Solution
The printer is switched on but the display does not light up.	<ul style="list-style-type: none"> ◆ Check the power supply. °
One or both LEDs light up red and printing is interrupted.	<ul style="list-style-type: none"> ◆ Check the software settings (driver settings) or command codes. ◆ Look for the error alert in the table in Section 3-3 Error alerts . ◆ Check whether the cutter is functioning normally and whether it is cutting at all. (Only if a cutter is installed.)
The label stock passes through the printer but no image is printed.	<ul style="list-style-type: none"> ◆ Please make sure that the label stock is loaded the right way up and that it is suitable material. ◆ Please make sure that the ribbon is loaded correctly.
The label stock jams during printing.	<ul style="list-style-type: none"> ◆ Clear the paper jam. Remove any label material left on the thermal print head and clean the print head using a soft lint-free cloth dipped in alcohol.
There is no printed image on part of the label or the image is blurred.	<ul style="list-style-type: none"> ◆ Check the thermal print head for dust or other dirt (label material or ribbon residue). ◆ Check for errors in the application software. ◆ Check the ribbon for wrinkles. ◆ Check the power supply. ◆ Run a self test (Section 3-2) and check the test print pattern to see whether the print head prints over the entire width of the medium. ◆ Check the quality of the print medium.
The printed image is positioned incorrectly or a label is missed out during printing.	<ul style="list-style-type: none"> ◆ Run the Label size calibration function. (Section 3-2) ◆ Check the label height setting. ◆ Check whether there is paper or dust covering the sensor. ◆ Check the paper guide settings.
The cutter does not cut off the labels in a straight line.	<ul style="list-style-type: none"> ◆ Check whether the label stock is positioned straight.
The cutter does not cut off the labels completely.	<ul style="list-style-type: none"> ◆ Check whether the label is more than 0.2 mm thick.
When using the cutter, the labels are not fed through or cut off incorrectly.	<ul style="list-style-type: none"> ◆ Check whether the cutter has been correctly installed. ◆ Check whether the paper guides are functioning correctly.
The label dispenser is not functioning normally.	<ul style="list-style-type: none"> ◆ Check whether there is dust on the label dispenser. ◆ Check whether the label stock is positioned correctly.

NOTE

- If any problems occur that are not described here, please contact your dealer.

IDENTjet M8 Print Engine Specifications

Model Name		IDENTjet M8
Print Method		Thermal Transfer / Direct Thermal
Resolution		300 dpi (12 dot/mm)
Print Speed		4 ips (102 mm/s)
Print Width		8.64" (219.5mm)
Print Length		Min. 1" (25.4 mm)** ; Max. 40" (1,016 mm)
Processor		32-bit RISC CPU
Memory	Flash	128 MB Flash (60 MB for user storage)
	SDRAM	32 MB
Sensor Type		Adjustable reflective sensor and transmissive sensor, central aligned
Media	Type	Continuous form, gap labels, black mark sensing, and punched hole; label length set by auto sensing or programming
	Width	Tear : Min. 4" (108 mm) – Max. 10" (255 mm) Cutter : Max. 8.5" (215.9 mm)
	Thickness	Min. 0.002" (0.06 mm) – Max. 0.01" (0.25 mm)
	Label roll diameter	External Label stand : 10" Max.
	Core diameter	Min. 1" (25.4 mm)-Max. 3" (76.2 mm)
Ribbon	Types	Wax, wax/resin, resin
	Length	Max.981' (300 m)
	Width	Min. 4.3" (110 mm) – Max. 8.66" (220 mm)
	Ribbon roll diameter	2.67" (68 mm) Max.
Printer Language	Core diameter	1" (25.4 mm)
	Label design software	EZPL, GEPL, GZPL, SD-PL, SD-EPL, SD-ZPL
Software	Driver	GoLabel (for EZPL only) Windows 2000, XP, Vista, Windows 7, 8.1 and 10 , Windows Server 2003 & 2008 · MAC · Linux
	DLL	Win CE, .NET, Andriod, Windows Mobile, Windows 2000 / XP / VISTA / Windows 7 / Windows 8.1/Windows 10
	Resident Fonts	6, 8, 10, 12, 14, 18, 24, 30, 16X26 and OCR A & B Bitmap fonts 90°, 180°, 270° rotatable, single characters 90°, 180°, 270° rotatable Bitmap fonts 8 times expandable in horizontal and vertical directions TTF Fonts (Bold / Italic / Underline), 0°,90°, 180°, 270° rotatable
Download Fonts	Bitmap Fonts	90°, 180°, 270° rotatable, single characters 90°, 180°, 270° rotatable
	Asian Fonts	16x16, 24x24. Traditional Chinese (BIG-5), Simplified Chinese (GB2312), Japanese (S-JIS), Korean (KS-X1001) 90°, 180°, 270° rotatable and 8 times expandable in horizontal and vertical directions TTF Fonts (Bold / Italic / Underline), 0°,90°, 180°, 270° rotatable
Barcodes	1-D Bar Codes	China Postal Code, Codabar, Code 11, Code 32, Code 39, Code 93, Code 128 (subset A, B, C), EAN-8, EAN-13, EAN 8/13 (with 2 & 5 digits extension), EAN 128, FIM, German Post Code, GS1 DataBar, HIBC, Industrial 2 of 5 , Interleaved 2-of-5 (12 of 5), Interleaved 2- of-5 with Shipping Bearer Bars, ISBT – 128, ITF 14, Japanese Postnet, Logmars, MSI, Postnet, Plessey, Planet 11 & 13 digit, RPS 128, Random Weight, Standard 2 of 5, Telepen, UPC-A, UPC-E, UPC-A and UPC-E with EAN 2 or 5 digit extension, UCC 128, UCC/EAN-128 K-Mart
	2-D Bar Codes	Aztec code, Code 49, Codablock F , Datamatrix code, MaxiCode, Micro PDF417, Micro QR code, PDF417, QR code, TLC 39
Code Pages		Codepage 437, 737,850, 851, 852, 855, 857, 860, 861, 862, 863, 865, 866, 869, Windows 1250, 1251, 1252, 1253, 1254, 1255, 1257 Unicode UTF8 · UTF16BE · UTF16LE
Graphics		Resident graphic file types are BMP and PCX, other graphic formats are downloadable from the software
Interfaces		<ul style="list-style-type: none"> • USB 2.0 (B-Type) • Serial port: RS-232 (DB-9) • IEEE 802.3 10/100 Base-Tx Ethernet port (RJ-45) • USB Host (A-Type) • Backlight 3.2" touch screen LCD • 1 Power on/standby button with dual colour LED backlight • 1 FEED / PAUSE / CANCEL button with dual colour LED : Ready (Green); Error (Red) • 1 Calibration button at rear panel
Control Panel		
RTC		Standard
Power		Auto Switching 100-240V AC, 50-60Hz
Environment	Operation temperature	41°F to 104°F (5°C to 40°C)
	Storage temperature	-4°F to 140°F (-20°C to 60°C)
Humidity	Operation	20-85%, non-condensing
	Storage	10-90%, non-condensing
Agency Approvals		CE (EMC) · FCC Class B · CB · UL · cUL · CCC
Dimension	Length	221 mm
	Height	224 mm
	Width	431 mm
	Weight	11.7 Kg, excluding consumables
Options		Cutter (Dealer Install)
		Parallel port adaptor module (Centronic female 36-pin)(Dealer Install)
		Bluetooth (Dealer Installer) Wireless LAN (IEEE 802.11 b/g/n) (Dealer Install)

* Specifications are subject to change without notice. All company and/or product names are trademarks and/or registered trademarks of their respective owners.

** Minimum print height and maximum print speed specification compliance can be dependent on non-standard material variables such as label type, thickness, spacing, liner construction, etc. We are pleased to test non-standard materials for minimum print height, and maximum print speed capability.

Appendix - Communication Port Specification

Communication Port Specification

- Parallel Port (Optional)

Handshaking : DSTB to printer,BUSY to PC or data input host.
 Interface cable : Compatible with IBM PC parallel cable
 Pinout : Details as below

Pin No.	Function	Transmitter
1	/Strobe	Computer / printer
2-9	Data 0-7	Computer
10	/Acknowledge	Printer
11	Busy	Printer
12	/Paper empty	Printer
13	/Select	Printer
14	/Auto-Linefeed	Computer / printer
15	N/C	
16	Signal Gnd	
17	Chassis Gnd	
18	+5V, max 500mA	
19-30	Signal Gnd	Computer
31	/Initialize	Computer / printer
32	/Error	Printer
33	Signal Ground	
34-35	N/C	
36	/Select-in	Computer / printer

- RS232

Default Setting: Baud rate 9600, no parity, 8 data bits, 1 stop bit, XON/XOFF protocol and RTS/CTS

RS232 Housing(9-pin to 9-pin)		
DB9 Socket		DB9 Plug
-	1 _____ 1	+5V, max 500mA
RXD	2 _____ 2	TXD
TXD	3 _____ 3	RXD
DTR	4 _____ 4	N/C
GND	5 _____ 5	GND
DSR	6 _____ 6	DTR
RTS	7 _____ 7	CTS
CTS	8 _____ 8	RTS
RI	9 _____ 9	N/C
Computer		Printer

- USB HOST Port

Computer Connector : Type A

Pin NO.	1	2	3	4
Function	VBUS	D-	D+	GND

- USB Port

Connector Type : Type B

Pin NO.	1	2	3	4
Function	NC	D-	D+	GND

- Ethernet (RJ-45)

PIN NO.	FUNCTION
1	Tx+
2	Tx-
3	Rx+
4	N/C
5	N/C
6	Rx-
7	N/C
8	N/C

Note

***The Maximum input current is 500 mA for Serial Port.

Appendix

Wi-Fi Setting

Manual of Wi-Fi Module Installation

Step 1. Turn Off the Power

Step 2. Insert the Wireless Module

Please follow the "Wireless Module Installation Manual" to insert the wireless module of IDENTjet M8

Step 3. The screen will display a grey Wi-Fi icon, and this means the printer has successfully detected the wireless module.



Appendix

Wi-Fi Setting

Matching the Wireless Access Point Through Touch Panel

Step 1. Turn on the printer and LCD panel will display

"Main menu"

Step 2. Select "Main"



Step 3. Select "Devices"



Step 4. Select "WIFI Settings"



Step 5. Select "Search Devices"



IDENTjet M8
USER MANUAL
Appendix
Wi-Fi Setting

Step 6. Wi-Fi device lists will pop-up
after a few seconds



Step 7. Choose the assigned Wi-Fi device
then press the ON button

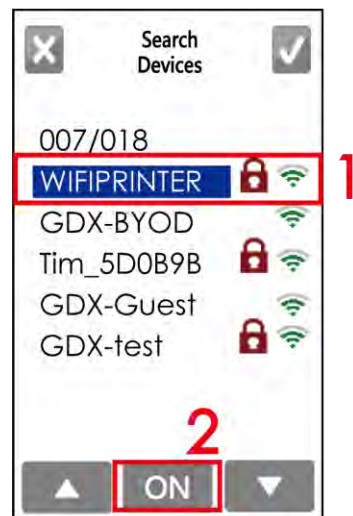

Step 8. Click on Password Column

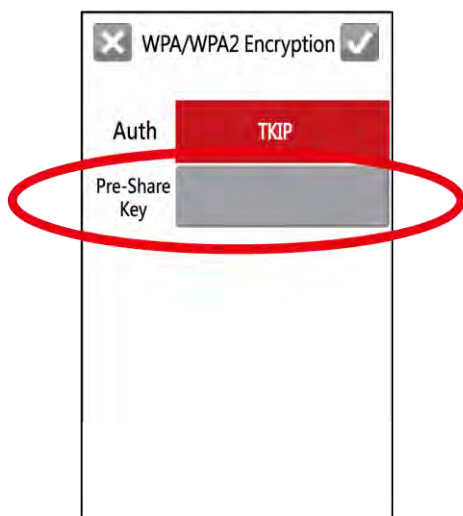

Step 9. Insert Password and Click



IDENTjet M8
USER MANUAL
Appendix
Wi-Fi Setting

Step 10. Click on again and connect to AP



Step 11. When Wi-Fi module is successfully installed, the printer will restart

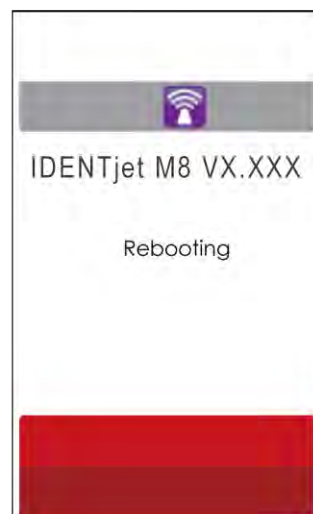

Step 12. If the Wi-Fi Icon turns purple, it means the printer is connected to a Wi-Fi device



Definition of Wireless Devices Interface

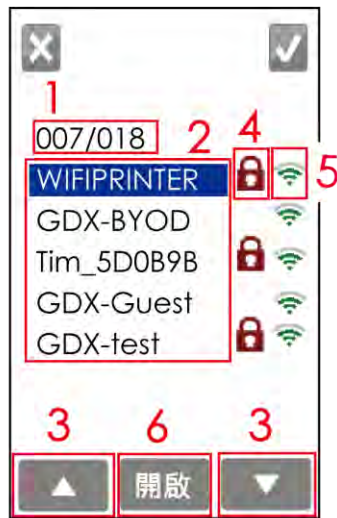

No.	Item	Explanation
1	Serial Number	Number of current connecting devices / Total device number
2	SSID	Lists of Wi-Fi options. It shows 5 devices at a time (Highlighted item is the current connecting device)
3	Up/Down	Click Up/Down button to switch the connecting devices
4	Password	It means the device needs password to connect
5	Signal Strength	The more bars it shows, the stronger the signal is it
6	Connecting Button	The button to connect with devices

USER MANUAL
Appendix
Wi-Fi Setting

How to connect to a wireless access point through OpenLABEL

Step 1. Open „OpenLABEL“ and click on the assigned printer model

Step 2. Press “OK”

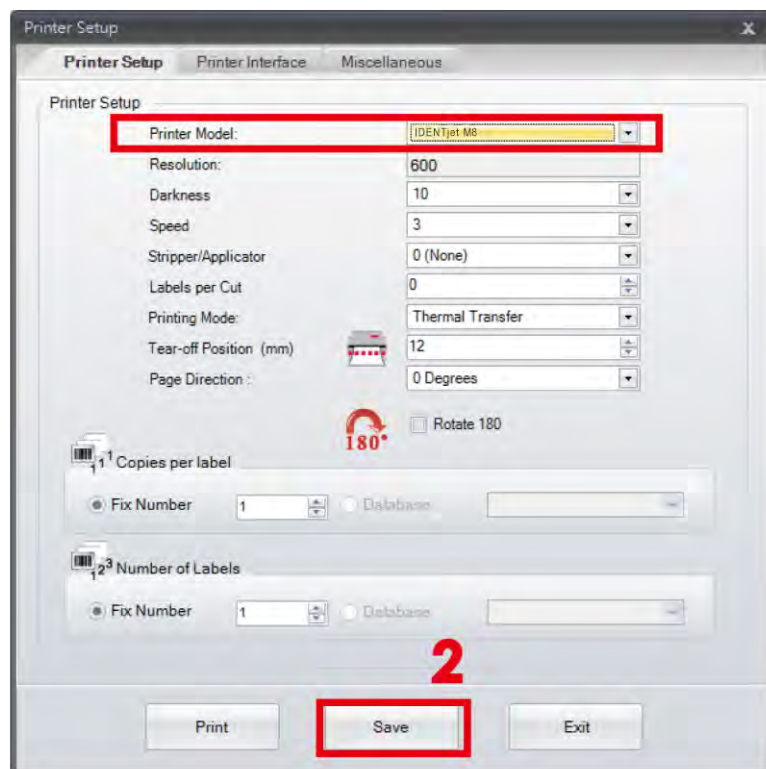

Step 3. Select "Network"

Step 4. Select "Wi-Fi Setting"



USER MANUAL
Appendix
Wi-Fi Setting

The tip to set Wi-Fi

Step 1. Pressing the <Setting Parameter> button

Step 2. Wait for three seconds, and the printer will restart.(It may vary per condition)

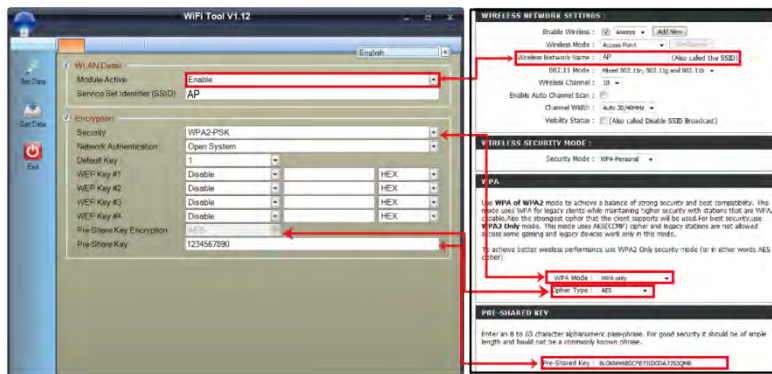

Step 3. After the printer restart, if the Wi-Fi icon turns purple, it means the printer is successfully connected to a Wifi device



Appendix

Bluetooth setting

Steps for setting bluetooth module

Step 1. Power off the printer

Step 2. Install the Bluetooth module

Note : Methods for installing Bluetooth module, please refer to Bluetooth module manual.

Step 3. A gray Bluetooth icon will be displayed in the main page after switching on the printer and it indicates that the printer has detected the Bluetooth module.



IDENTjet M8
USER MANUAL
Appendix
Bluetooth setting

Steps for setting Bluetooth keyboard

Active the Bluetooth keyboard to be detectable

Step 1. Press "Connect" button. After connecting to a Bluetooth keyboard, the printer will detect Bluetooth keyboard automatically, as the figure indicates below.



Step 2. The indicator at the upper left corner of Bluetooth keyboard will flash blue when it has been detected.

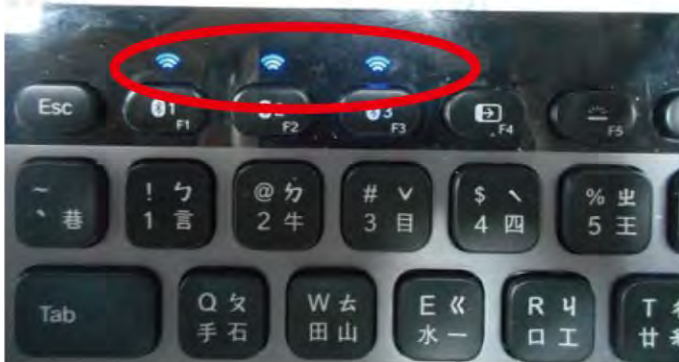

Step 3. The indicator will stop flashing if the Bluetooth keyboard connects to printer properly.



IDENTjet M8
USER MANUAL
Appendix
Bluetooth setting

Steps for setting bluetooth connection on the LCD panel

Step 1. Turn on the printer and
LCD panel will display " Main menu"

Step 2. Select " Main"



Step 3. Select "Devices"



Step 4. Select " Bluetooth Settings"



Set "Profile" into "HID Mode" and
then click "Search Devices"

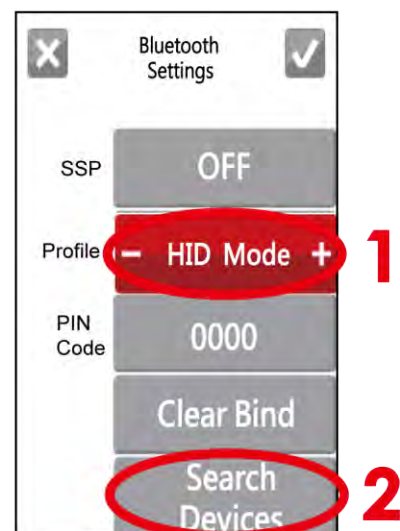

IDENTjet M8
USER MANUAL
Appendix
Bluetooth setting

Step 6 . The LCD panel will display "Waiting" when the printer detects the Bluetooth keyboard (figure left).

When the Bluetooth keyboard is detected by the printer, the monitor will indicate the information of Bluetooth keyboard (figure right).

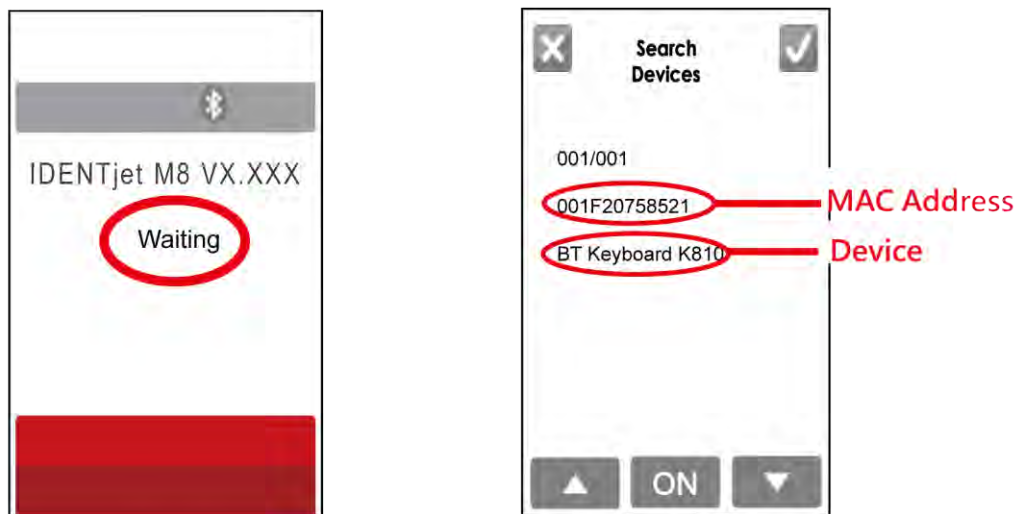

Step 7 . Press "ON" button on the LED panel to create a connection between the printer and the Bluetooth keyboard, and then the LCD panel will display " Please Enter PIN Code " .

Enter the "PIN Code" into the printer via the Bluetooth keyboard.

Note : The "PIN Code" does not need to be entered if the "SSP" of the printer and the Bluetooth keyboard is set "ON" .



IDENTjet M8
USER MANUAL
Appendix
Bluetooth setting

Step 8 . When the connection is successfully created, the current panel will be automatically switched to the setting menu of Bluetooth, as the figure below indicates.

(The upper left corner of Bluetooth keyboard will stop flashing at this time.)

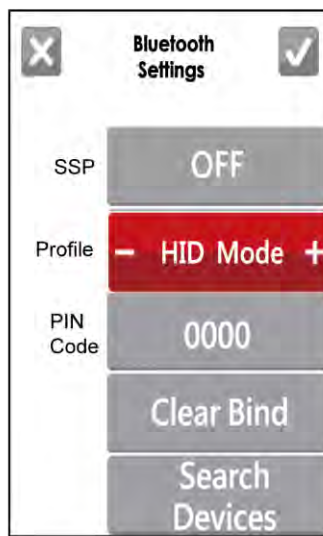

If the current panel is switched to main menu, the LCD panel will display "Bluetooth" and "Keyboard" icons, as the figure below indicates.



IDENTjet M8
USER MANUAL
Appendix
Bluetooth setting

Steps for creating the connection between cellphone and printer via bluetooth

Set the bluetooth value of the printer

Step 1. Power on the printer and LCD panel displays " Main manu"

Step 2. Select " Main"



Step 3. Select " Device"



Step 4. Select " Bluetooth settings"



Step 5. Set "Profile " into "SPP Mode" .

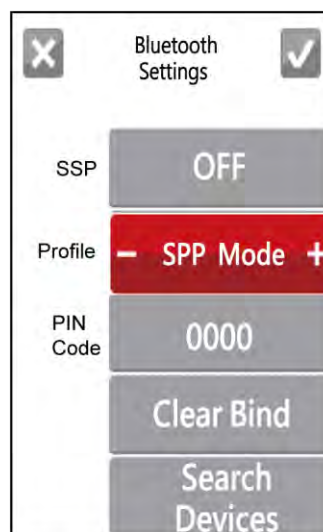

IDENTjet M8
USER MANUAL
Appendix
Bluetooth setting

Set the bluetooth function of the mobile phone

(The App only support Android system and the methods of setting Bluetooth may vary from each mobile phone .)

Step 1. Open "Setting menu of mobile phone and select "Bluetooth" .

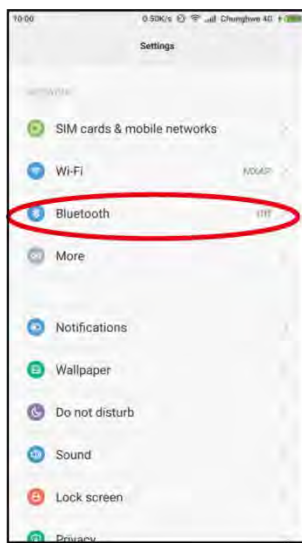

Step 2. After selecting "Open" of Bluetooth, mobile phone will automatically detect Bluetooth devices. Select the desired device name. After the connection is successfully created, the mobile phone will display the matched device name, as the figure below indicates.

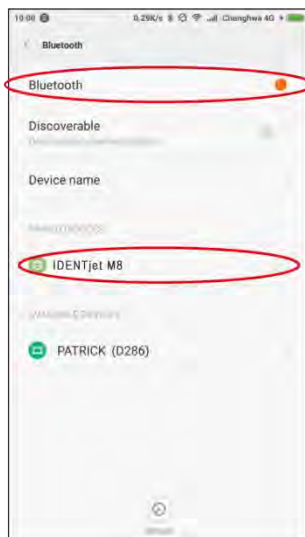

IDENTjet M8
USER MANUAL
Appendix
Bluetooth setting

Step 3. Activate the APP

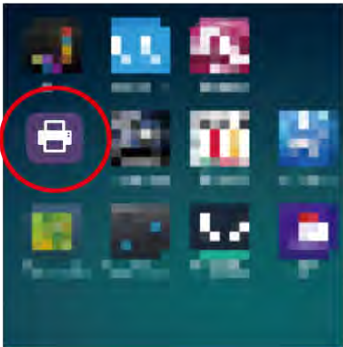

Step 4. Select the icon at the bottom right of the APP

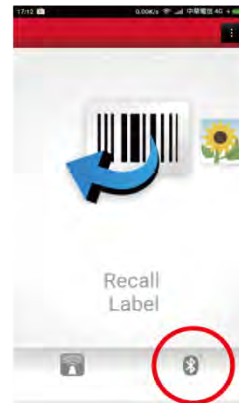

Step 5. Select the desired device name and MAC Address

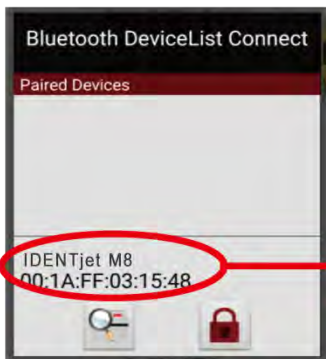

Device name
and MAC Address

Step 6. The icon at the bottom right of the APP will turn blue when the mobile phone and Bluetooth are properly connected.

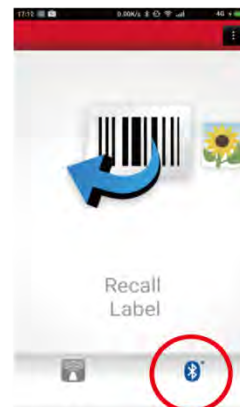

IDENTjet M8
USER MANUAL
Appendix
Bluetooth setting

Steps for creating the connection between PC and printer via bluetooth

Set bluetooth parameters of the printer

Step 1. Power on the printer and LCD panel displays "Main manu"

Step 2. Select "Main"



Step 3. Select "Devices"



Step 4. Select "Bluetooth settings"

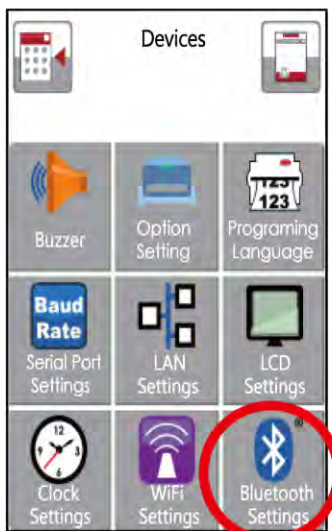

Step 5. Set "Profile" into "SPP Mode"

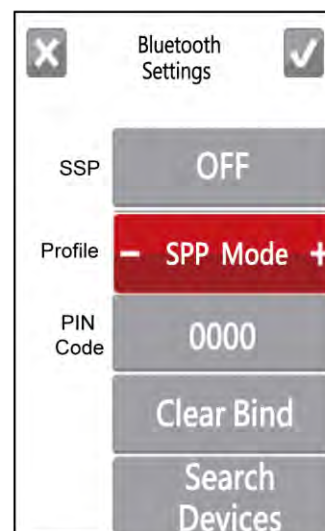

IDENTjet M8
USER MANUAL
Appendix
Bluetooth setting

Activate "BlueSoleil Space" and create the connection after inserting the Bluetooth device into the slot of PC Mainframe

Step 1. Insert the Bluetooth device into the slot of PC Mainframe



Step 2. Activate "BlueSoleil Space"

(Each Bluetooth device has its compatible software)



Step 3. Select the desired icon with the mouse and right-click on the mouse to select "Turn on Bluetooth"
(The Bluetooth device now lights up in green.)

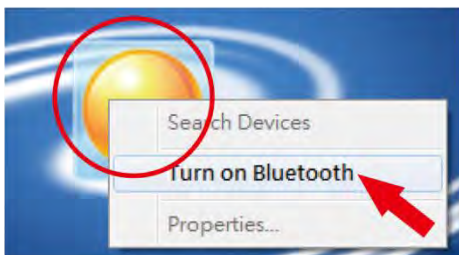

Step 4. Right-click on the mouse and select "Search Devices"

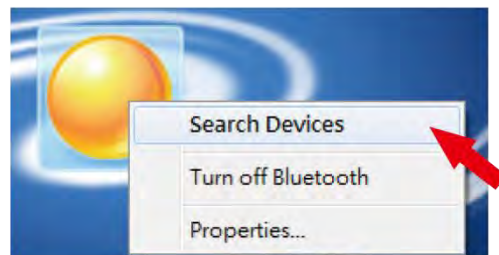

Step 5. The detected device will display "00:1A:FF:XX:XX:XX"



Step 6. Right-click on the mouse and select "Get Device Name" and the icon of the printer will display IDENTjet M8.



IDENTjet M8
USER MANUAL
Appendix
Bluetooth setting

Step 7. Right-click on the mouse and select " Connect Bluetooth Serial Port" (see the left figure below),
Then, the screen displays a message of establishing a connection, as the right figure below indicates.



Step 8. Input the Bluetooth code :0000 (default)

Note : The Bluetooth code does not need to be inputted when the SSP mode of the Bluetooth setting in the printer and the PC is set "Activated" .

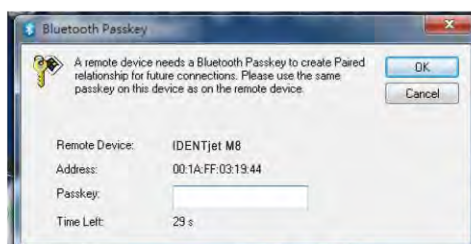

The icon of the printer lights up green when the connection between PC and the printer is successfully created.



Appendix

Bluetooth setting

Introduction of the Bluetooth parameters

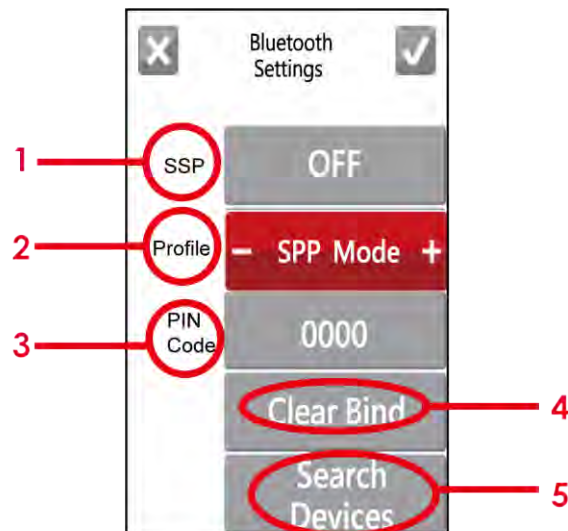

1	SSP	The Bluetooth code is not needed to be inputted when the SSP mode of the Bluetooth setting in the printer and the PC/Keyboard is set "Activated" . Please select "Clear Bind" , you are allowed to change the setting after the connection is successfully created.
2	Profile	It can be switched to SPP mode or HID mode. SPP mode: For creating the connection of PC or mobile phone HID mode: For creating the connection of Bluetooth keyboard and Bluetooth scanner. Please select "Clear Bind" , you are allowed to change the setting after the connection is successfully created.
3	PIN Code	Code of printers and Bluebooth. Please select "Clear Bind" , you are allowed to change the setting after the connection is successfully created.
4	Clear Bind	It deletes connections of Bluetooth devices.
5	Search Devices	It scans Bluetooth devices when pressing the button. It shows information of devices when the searching is completed. 1. It only supports HID 2. It only shows English and numbers. 3. It shows maximum 16 pairs information of devices * It disconnects current connection when functioning, after creating a successful connection.

APPENDIX

FILE MANIPULATION WHEN USING USB STICK

File Manipulation

The files in both devices (USB memory stick and printer internal Flash memory) are able to copy and move by the commands “~MCPY” and “~MMOV” that sends from GoLabel on a PC via either connection - USB or Ethernet ports.

- Copy

Syntax	~MCPY,s:o,x,d:o,x
Description	Copy file from USB memory stick to Flash memory, or vise-versa
Parameter	<p>s = source device of stored object;</p> <ul style="list-style-type: none"> • “D” for USB memory stick; “F” for internal Flash memory <p>d = destination device of stored object</p> <ul style="list-style-type: none"> • “D” for USB memory stick; “F” for internal Flash memory <p>o = object name (file name); the name “o” is substituted for “*”</p> <p>x = extension (file type), the type “x” is substituted by “*”, or following either one: D= database, A= Asia font, C= TTF font, E= Bit-Mapped font, F= label format, G= graphic, S= serial file, T= text, B= Unicode Table.</p>
Example	<p>~MCPY,F:*.F,D:*.F (Copy entire “Label Format” files from Flash memory to USB memory stick)</p> <p>~MCPY,D:*.G,F:*.G (Copy entire “Graphic” files from USB memory stick to Flash Memory)</p> <p>~MCPY,D:*.*,F:*. * (Copy all object files from USB memory stick to Flash Memory)</p>

- Move

Syntax	~MMOV,s:o,x,d:o,x
Description	Move files from USB memory stick to Flash memory or vise-versa
Parameter	<p>s = source device of stored object;</p> <ul style="list-style-type: none"> • “D” for USB memory stick; “F” for internal Flash memory <p>d = destination device of stored object</p> <ul style="list-style-type: none"> • “D” for USB memory stick; “F” for internal Flash memory <p>o = object name (file name); the name “o” is substituted for “*”</p> <p>x = extension (file type), the type “x” is substituted by “*”, or following either one: D= database, A= Asia font, C= TTF font, E= Bit-Mapped font, F= label format, G= graphic, S= serial file, T= text, B= Unicode Table.</p>
Example	<p>~MMOV,F:*.F,D:*.F (Move entire “Label Format” files from Flash memory to USB memory stick)</p> <p>~MMOV,D:*.G,F:*.G (Move entire “Graphic” files from USB memory stick to Flash Memory)</p> <p>~MMOV,D:*.*,F:*. * (Move all object files from USB memory stick to Flash Memory)</p>